



## Monitoring return condensate and boiler feed water by use of the multi-stream Quick-TOC-condensate analyser with gas validation

By: Piet Broertjes  
Project Sales Engineer  
ODS Sampling & Analytical Systems; The Netherlands





# Agenda

- Return Condensate Applications: Guidelines for TOC-levels in boiler feed water and return condensate
- Typical analytical problems at low TOC-levels
- Different TOC-methods and their features
- Quick-TOC-condensate features
- The advantages of gas validation
- Design of multi-stream applications
- How to detect sample flow alarms
- How does it look like





## TOC & Oil: ASME, VGB, EPRI, HSRG

### VGB/VdTÜV, All Pressure Levels

**Table 8.1.1**  
**VGB Table 1**

Parameter		Normal Operating Limit	Remarks
pH (25 °C)	-	9-10	1)
Cation Conductivity (25 °C)	µS/cm	< 0.2	2)
Iron (Fe)	mg/l	< 0.02	
Copper (Cu)	mg/l	< 0.003	
Silica (SiO <sub>2</sub> )	mg/l	< 0.02	
Sodium (Na)	mg/l	< 0.01	
Oxygen (O <sub>2</sub> )	mg/l	< 0.10	3)
Total Organic Carbon (TOC)	mg/l	< 0.2	4)

#### Remarks

- 1) The pH in feedwater shall be achieved by dosing volatile alkalizing agents (Ammonia, NH<sub>3</sub>), since feedwater will be used as desuperheater spray water. See also General Remark 3.
- 2) Continuous Measurement
- 3) When the cation conductivity of the feedwater is > 0.2 µS/cm for several days, oxygen concentration shall be < 0.02 mg/l
- 4) TOC shall be as low as practically possible.





## TOC & Oil: ASME, VGB, EPRI, HSRG

**Table 2**  
**Feed Water Guidelines**

Drum Pressure, psig	15-300	301-600	601-900	901-1000	15-1000 (AVT)	1000-1500	>1500
pH, all ferrous heaters	9.3 – 10.0	9.3 – 10.0	9.3 – 10.0	9.3 – 9.6	9.3 – 9.6	9.3 – 9.6	9.3 – 9.6
pH, copper – bearing heaters	8.8 – 9.2	8.8 – 9.2	8.8 – 9.2	8.8 – 9.2	8.8 – 9.2 (a)	8.8 – 9.2	8.8 – 9.2
Total hardness, as ppm CaCO <sub>3</sub> , max	0.3	0.2	0.1	0.05	0.003	ND	ND
Oxygen, ppm max (b)	0.007	0.007	0.007	0.007	0.007	0.007	0.007
Iron, ppm max	0.1	0.03	0.02	0.02	0.01	0.01	0.01
Copper, ppm max	0.05	0.02	0.01	0.01	0.005	0.005	0.002
Organic, ppm TOC max (c)	1	1	0.5	0.2	0.1	0.2	0.2
Cat. Conductivity, μS/cm max	-	-	-	-	0.2	0.5 / 0.2 (d)	0.2 (e)
Hydrazine, ppm	-	-	-	-	0.02	0.02	0.02
Silica, ppm SiO <sub>2</sub> (f)	-	-	-	-	-	0.2	0.1
Oily Matter (mg/l), max	1.0	0.5	0.5	ND	ND	ND	ND

- (a) AVT not recommended for copper-bearing cycles and associated low feedwater pH where the drum pressure is less than 400 psig  
 (b) 0.002 ppm of oxygen should be retained in the boiler feedwater as a minimum.  
 (c) TOC – Total Organic Compound  
 (d) Cation conductivity – A phosphate treatment is first number / the second number is for an AVT program  
 (e) AVT program / phosphate programs not recommended above 1500 psig  
 (f) Because of its volatility, the feedwater silica concentration cannot significantly exceed the maximum concentration permitted in the steam.  
 When the steam goes to a turbine, this limit is often between 0.020 and 0.010 ppm.  
 (g) All values represent maximum allowable





## TOC & Oil: ASME, VGB, EPRI, HSRG

### EPRI, All Pressure Levels

#### Note:

In case the flow for the IP and/or HP system originates directly from the LP drum, table 4.1.2 is not valid. In stead reference is made to paragraph 5.2.

**Table 4.1.2**  
**EPRI figure 3.1**

Parameter		Normal Operating Limit	Remarks
pH (25 °C)	-	9.2 - 9.6	1), 4)
Cation Conductivity (25 °C)	µS/cm	< 0.2	2)
Silica (SiO <sub>2</sub> )	ppb	< 10	5)
Sodium (Na)	ppb	< 5	
Oxygen (O <sub>2</sub> )	ppb	< 10	6)
Iron (Fe)	ppb	< 5	
Total Organic Carbon (TOC)	ppb	< 200	3)

#### Remarks

- 1) The pH in feedwater shall be by volatile alkalizing agents (Ammonia, NH<sub>3</sub>), since feed water will be used as desuperheater spray water (see also General Remark 3).
- 2) Continuous Measurement
- 3) TOC shall be as low as practically possible.
- 4) NEM recommends a pH range of 9 - 10.
- 5) For HRSRG's without reheat SiO<sub>2</sub>, < 20 ppb is allowed.
- 6) NEM strongly recommends an oxygen concentration of > 5 ppb and allows an upper limit of 20 ppb.





## TOC & Oil: ASME, VGB, EPRI, HSRG

UFC 3-240-13FN  
25 May 2005

Table 3-11. ASME Feedwater Limits for Industrial Water Tube Boilers

Feedwater Property	0 - 2068 KPa (0 - 300 psig)	2075-3103 KPa (301-450 psig)	3110 - 4137 KPa (451 - 600 psig)	4144 - 5171 KPa (601 - 750 psig)	5178 - 6205 KPa (751 - 900 psig)	6212 - 6895 KPa (901 - 1000 psig)	6902-10,342 KPa (1001 - 1500 psig)	10,349-13,790 KPa (1501 - 2000 psig)
Dissolved oxygen (ppm O <sub>2</sub> ) before adding chemical oxygen scavenger	< 0.007	< 0.007	< 0.007	< 0.007	< 0.007	< 0.007	< 0.007	< 0.007
Total iron ppm Fe (as Fe)	≤ 0.1	≤ 0.05	≤ 0.03	≤ 0.025	≤ 0.02	≤ 0.02	≤ 0.01	≤ 0.01
Total copper ppm Cu (as Cu)	≤ 0.05	≤ 0.025	≤ 0.02	≤ 0.02	≤ 0.015	≤ 0.01	≤ 0.001	≤ 0.001
Total Hardness ppm (as CaCO <sub>3</sub> )	≤ 0.03	≤ 0.03	≤ 0.02	≤ 0.02	≤ 0.1	≤ 0.05	ND	ND
pH at 25 °C (77 °F)	8.3-10.0	8.3-10.0	8.3-10.0	8.3-10.0	8.3-10.0	8.3-9.6	8.3-9.6	8.3-9.6
Chemicals for pre-boiler system	NS	NS	NS	NS	NS	VAM	VAM	VAM
Non-volatile TOC ppm (as O <sub>2</sub> )	< 1	< 1	< 0.5	< 0.5	< 0.5	< 0.2	< 0.2	< 0.2
Oily matter ppm	< 1	< 1	< 0.5	< 0.5	< 0.5	< 0.2	< 0.2	< 0.2

NOTES:

1. Makeup water percentage: Up to 100% of feedwater.
2. Assumes existence of deaerator.
3. Conditions: Includes superheater, turbine drives, or process restriction on steam purity.
4. Saturated steam purity target as shown.
5. NS = not specified.
6. ND = not detectable.
7. VAM = Use only volatile alkaline materials upstream of a temporary water source.





# Typical analytical problems at low TOC levels

Problems
Zero drift
Span drift
Sensitivity / lowest detectable limit
Contamination by CO <sub>2</sub> /C <sub>x</sub> H <sub>y</sub> from ambient air or carrier gas or chemicals
Memory due to absorption and adsorption effects
Recovery
Carry over effects
Response time and cycle time
Validation and calibration

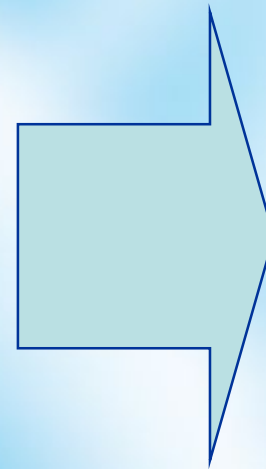

How to solve these problems?





# Analyser selection: What's on the market

	UV-persulphate	Oxidation by ozone hydroxyl radicals	UV-oxidation – delta conductivity	Catalytical combustion – batch type	Thermal oxidation – batch type 1200 °C.
High sensitivity	Suitable	No	Extremely / yes	Yes	Yes
Low drift	No	No	Yes	Yes	Yes
High recovery	Not for all components	Questionable	Questionable	Yes, with some exceptions	Yes / 100% guaranteed
Fast response	No	No	Suitable	Yes	Yes
Low carry over	No	No	Questionable	Yes	Yes
Contamination by CO2 via ambient air	Questionable	Yes /especially in caustic	Possible	Possible	No, closed loop injection at 0,4 bar
Interference by matrix/pH	No	No	Questionable	No	No
Oxidizers/chemicals	Yes, uses a lot of persulphate	Uses a lot of acid and caustics	Yes	No	No
Suitable for return condensate	Yes, but higher ranges and slow response	Questionable. Only high ranges	Questionable: Interference and high memory effects	Suitable but more memory and some blind value effects	Excellent and fastest technique





# Quick-TOC-condensate features

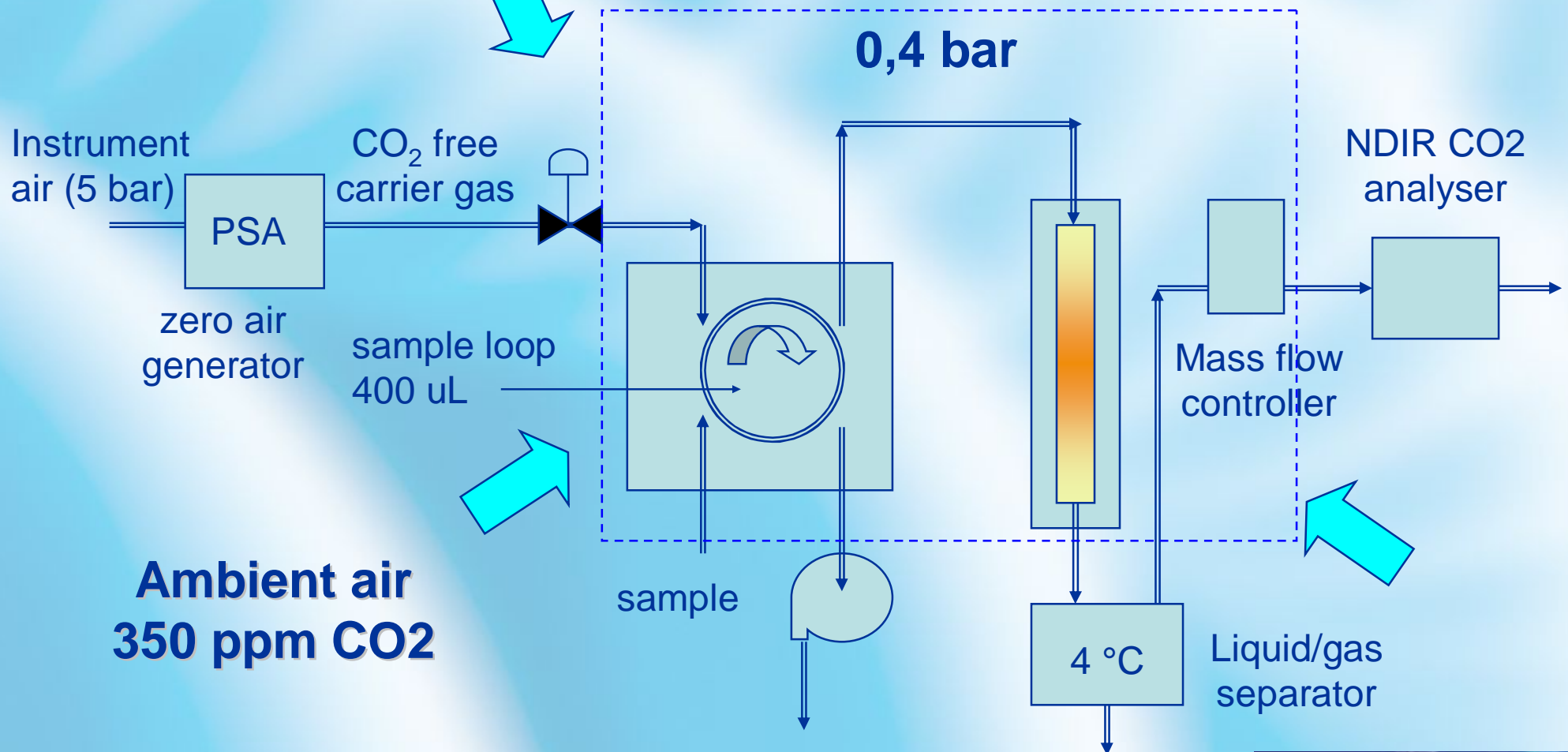



## Multi loop injection



This animation shows a multi-loop-injection of 3 times

*Normally:  
3 seconds on  
3 seconds off  
3 a 5 minutes cycle.*

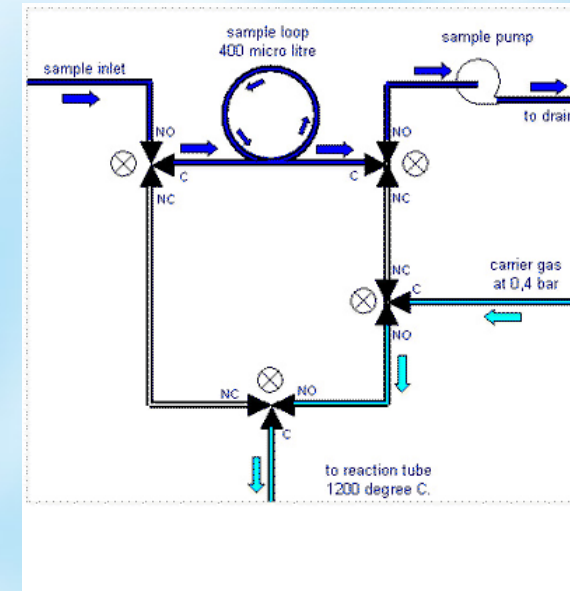

Four 3-way valves switch simultaneously on/off. During every cycle the sample loop is filled with 400 micro litre of sample and then this loop content is injected into the 1200 °C. reactor tube where all organic carbons are completely oxidized to CO<sub>2</sub>.

At Low ranges we use the multi injection technique. The loop content is injected fast several times for one analyses result.





# Thermal Oxidation & Peak Integration

1200 °C oxidation

All reactor materials  
are ceramic



Scale:  
CO<sub>2</sub>  
0-20 mA

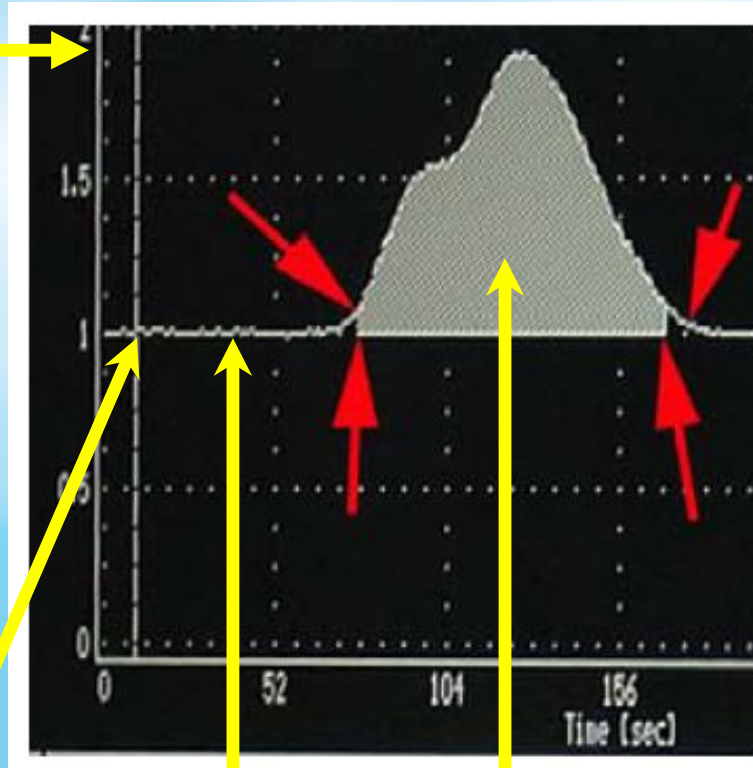

Scale:  
seconds

injection

auto zero

peak integration mAsec





## Why using the peak integration method

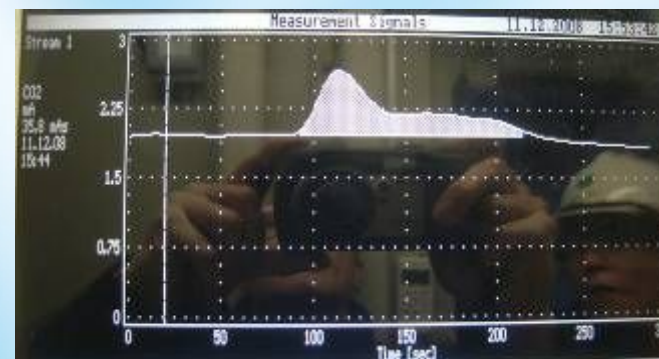
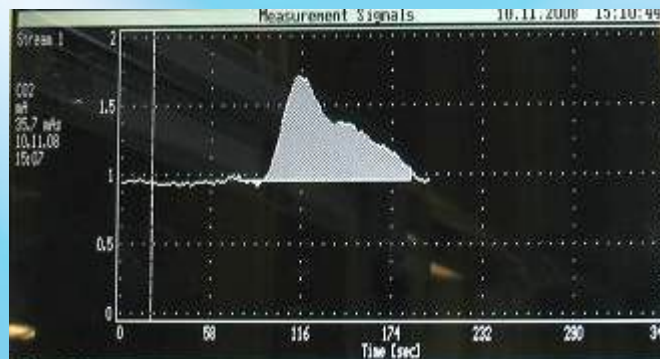
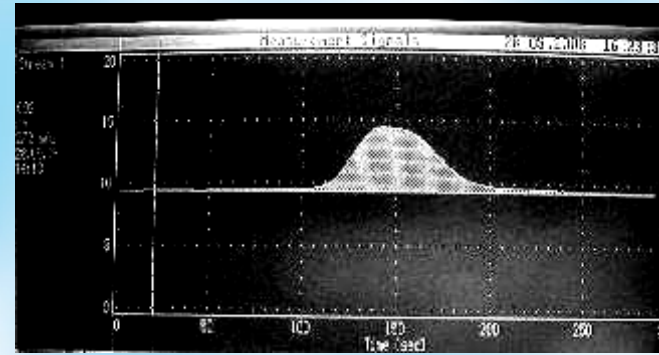
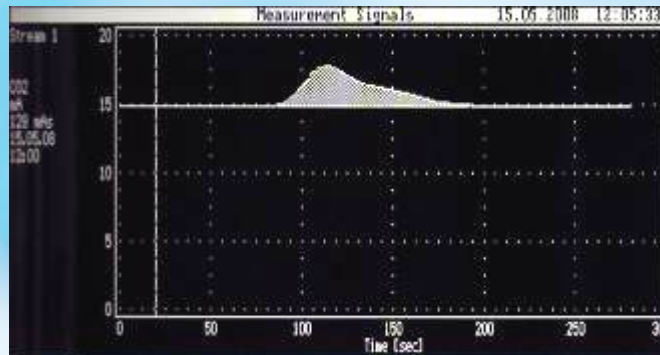

Same analyser installation (Quick-TC-loop; range 2 mg/l C.)

- Several single components
- Result .... different peak shapes!





# Why is the TOC zero- and span stability important?

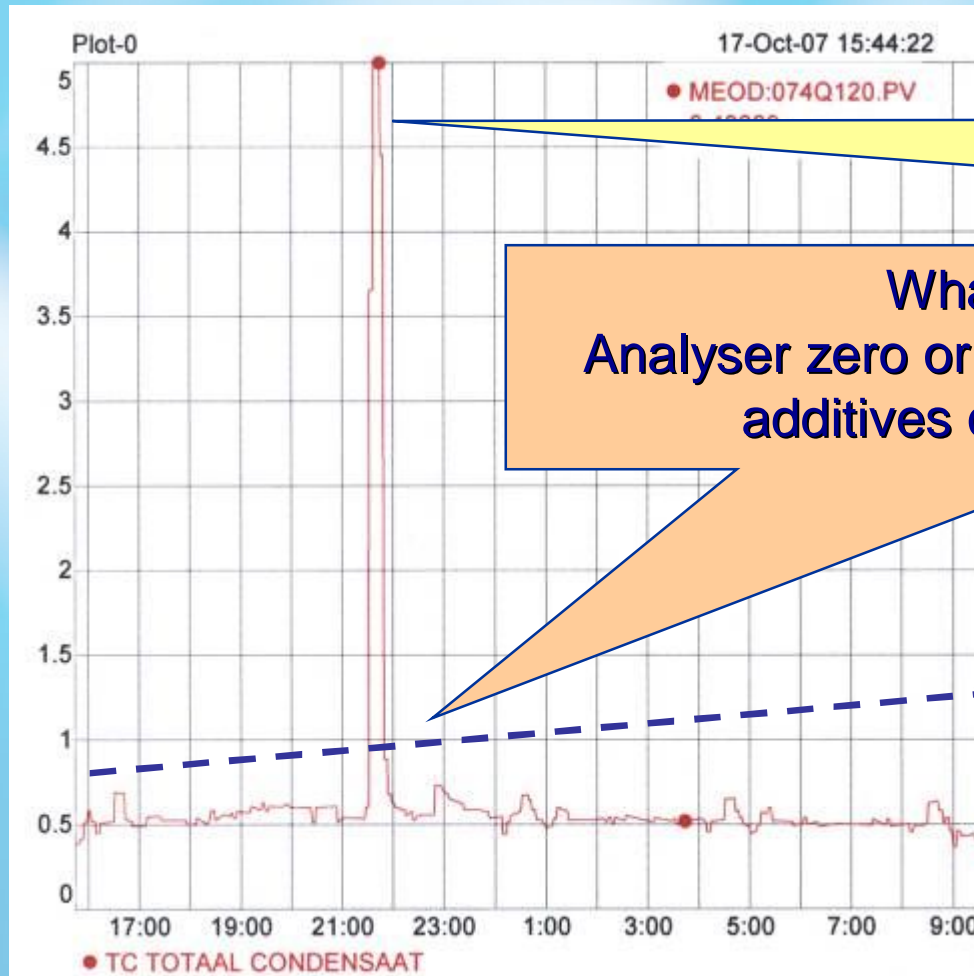

Peak because of a leak in a heat exchanger. Fast and reliable!!

What do we observe now?  
Analyser zero or - span drift or an increasing level of additives or a heat exchanger leak ???

TC background due to the dosing of oxygen scavenger.  
We can check the dosing of this costly chemical!

Zero stability  
0 mg/litre C. per year





## Solutions

Problems	Solution
Zero drift	Injection technique and auto zero
Span drift	Constant loop injection volume and peak integration
Sensitivity / lowest detectable limit	Multi sample loop injection (400 – 4000 $\mu$ L)
Contamination by CO <sub>2</sub> /C <sub>x</sub> H <sub>y</sub> from ambient air or carrier gas or chemicals	Closed loop system at 0,4 bar over pressure
Memory due to absorption and adsorption effects	All wetted parts are Inert materials and being flushed
Recovery	At 1200 °C all TOC is combusted
Carry over effects	No catalyst and 1200 °C combustion
Response time and cycle time	Complete and rapid combustion at 1200 °C
Validation and calibration	Unique patented gas validation technique





## Calibration with wet chemical standards

How to calibrate a 200 µg/litre C. or even more sensitive analyser?

- Where to get blanc water?
- How to prepare the standard?
- How clean are all the wetted parts that are used?
- How to avoid CO<sub>2</sub> being absorbed into the wet standard?
- How long can the standard be stored?

**That is a very important problem!!!**

From practice: An operator told us:

*“My problem is not to maintain the analyser. That is easy. My problem is that when the analyser suddenly reads a high TOC the operator runs in and tells me my analyser is not analysing correctly and that he is loosing expensive steam for no reason. How can I prove him fast and accurate that it is not the analyser but the contaminated steam causing the high TOC-reading?”.*





# Validation procedure using calibration gas

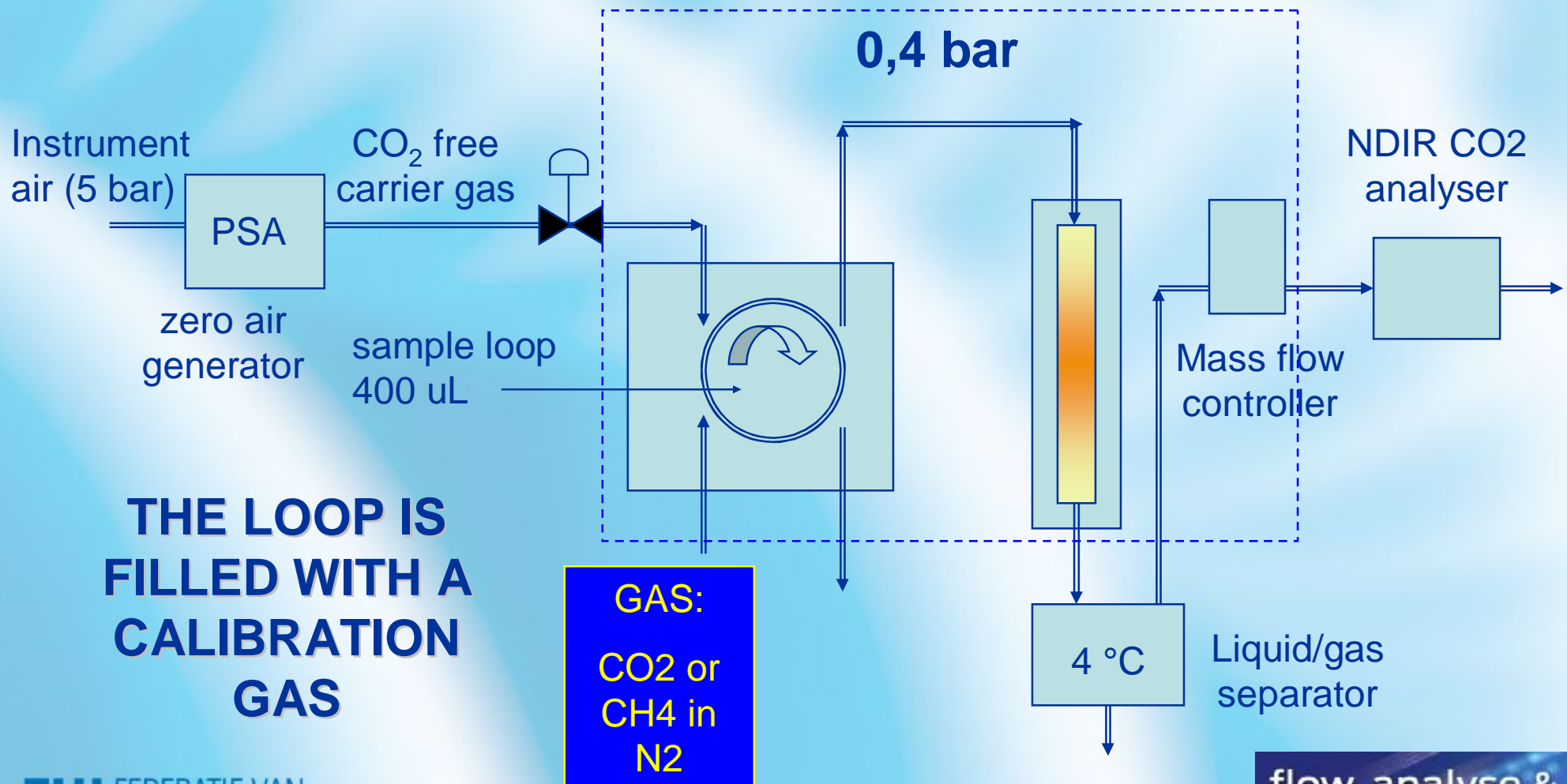



# Validation procedure using calibration gas

Single measurement stream 1

	TC m/s	TIC m/s	Tm m/s	TC ug/l	TIC ug/l
1	69.2			704	
2	64.6			658	
3	64.5			657	
4	61.3			625	
5	60.6			617	
6	62.4			636	
7					
8					
9					
10					
Mean	62.7			630	
CV	2.9%			2.9%	

0% 25% 50% 75% 100% Single measurement

F10 - Back to Service Menu      F3 - Measuring s  
 F1 - Help                              F4 - Calibrations      F5 - Print





# Validation procedure using calibration gas

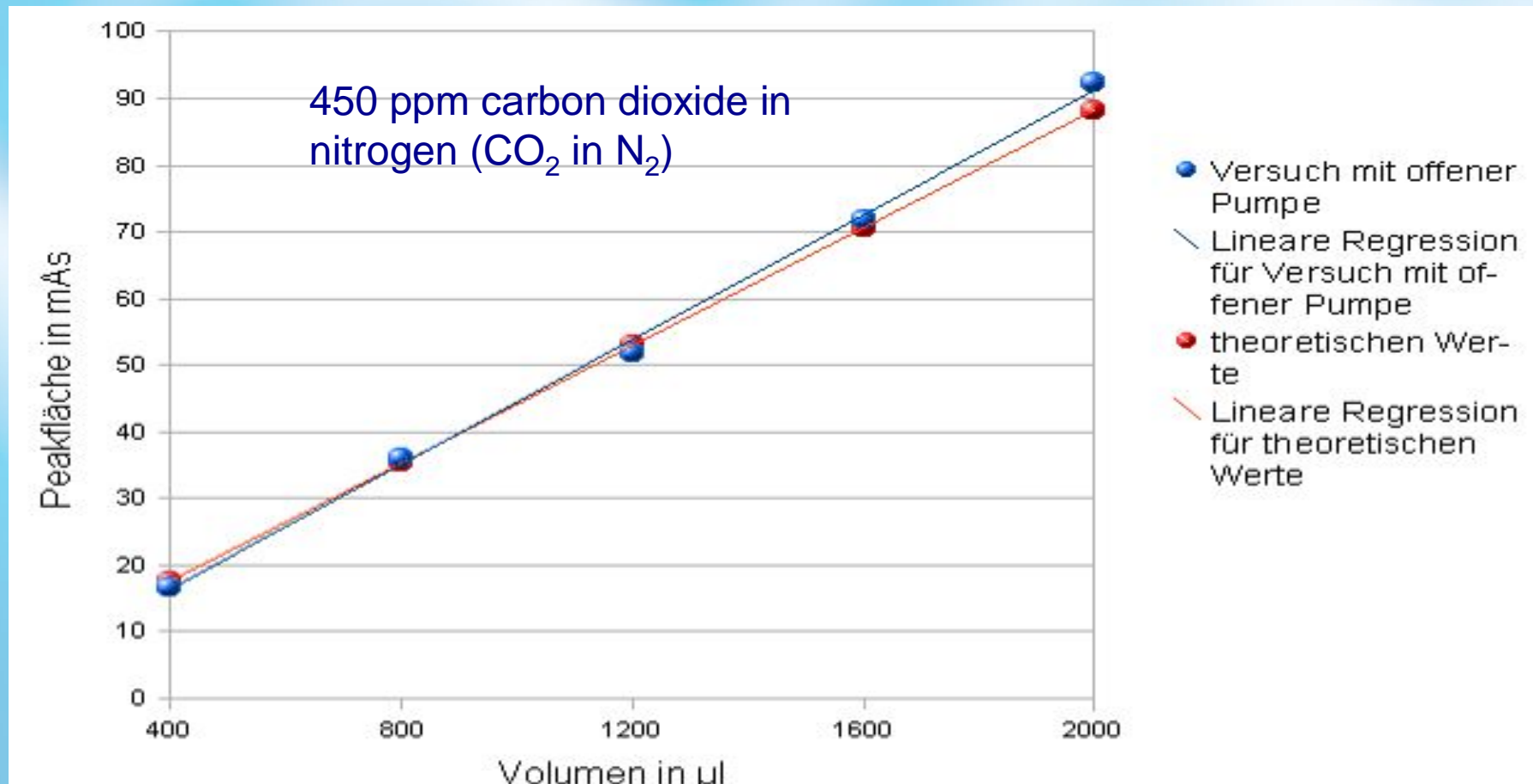



# Validation procedure using calibration gas

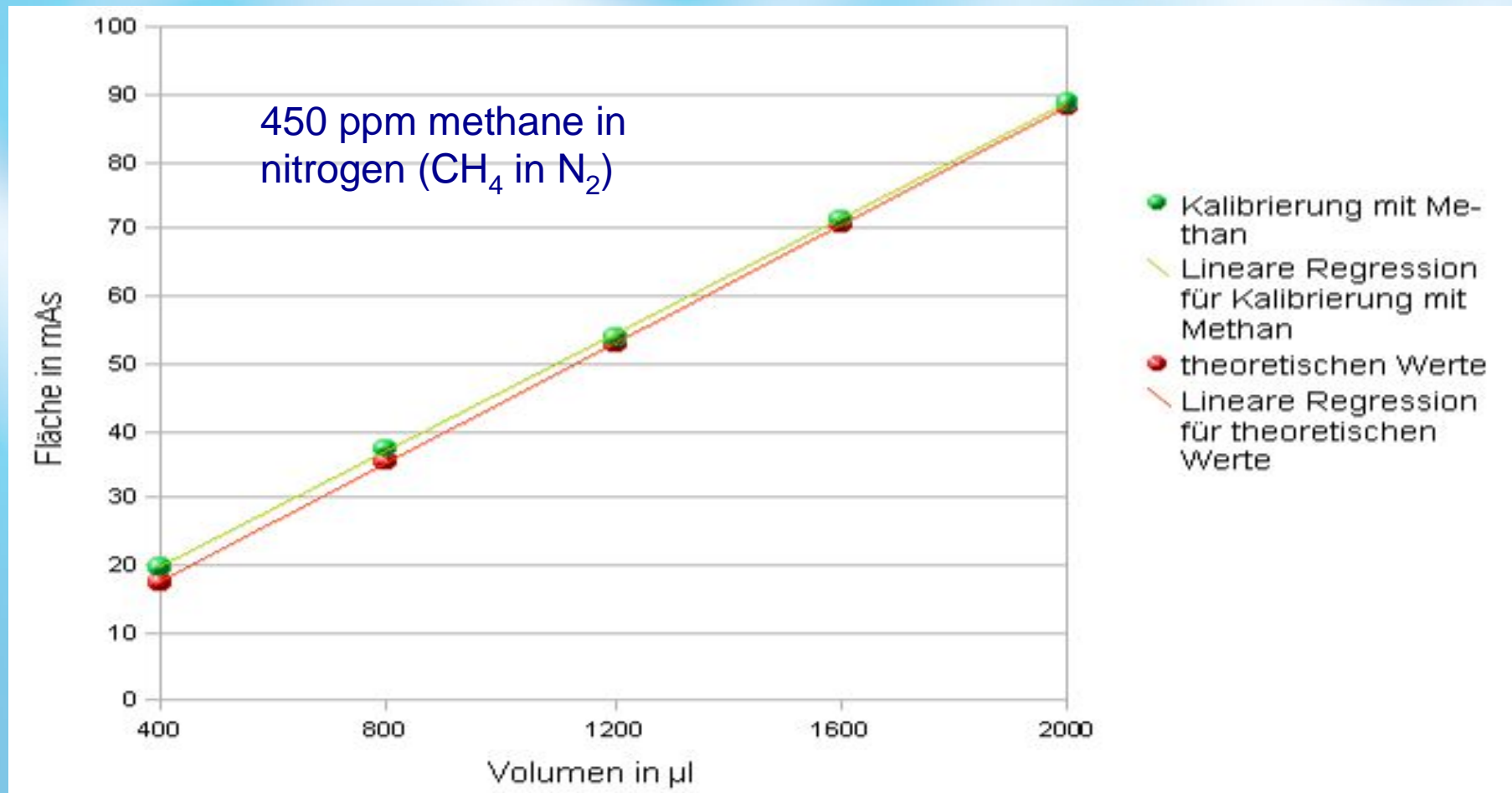



# Why using a multi stream TOC-analyser

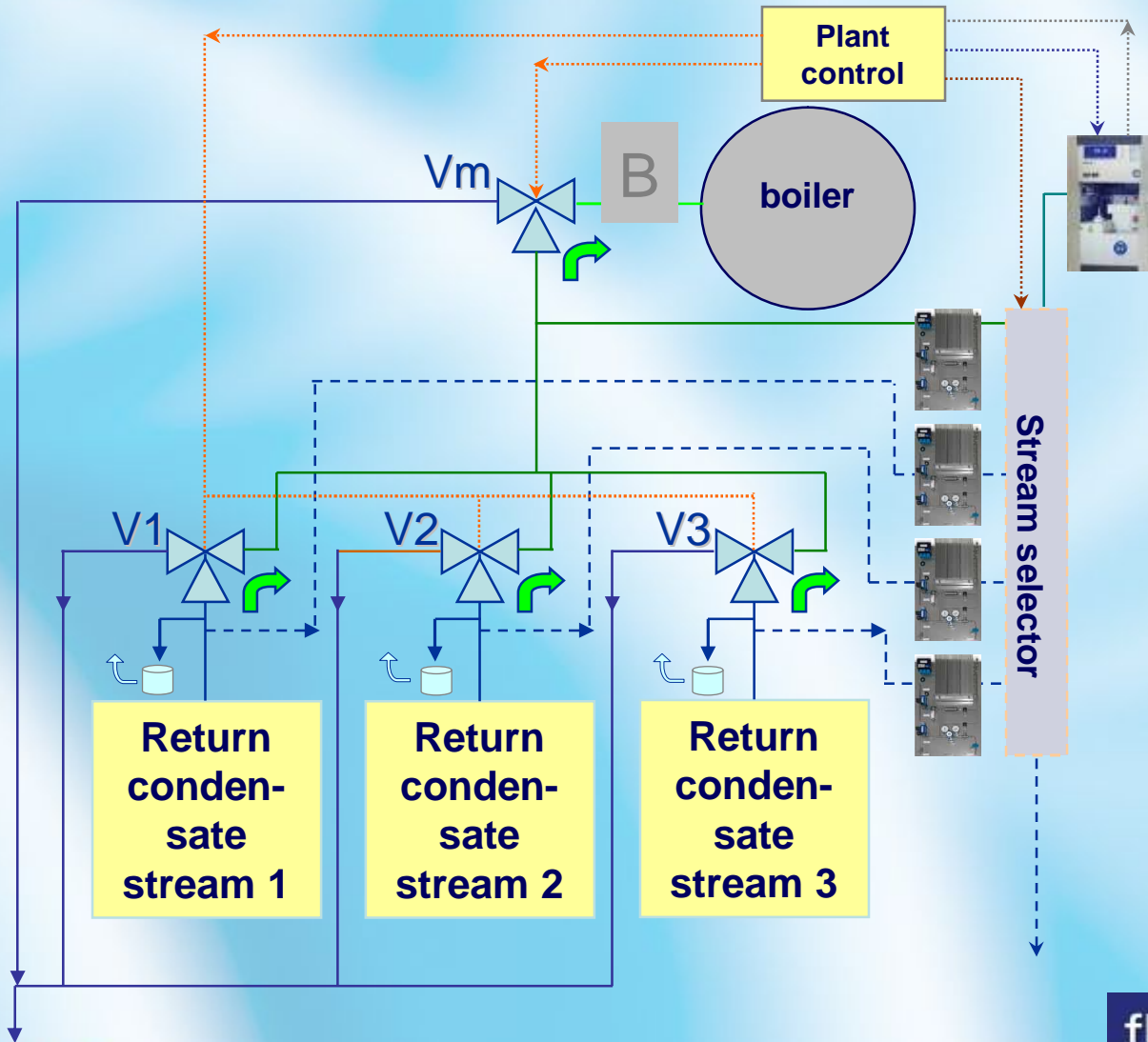



# Stream selectors: 3-way valve system

Water Coolers  
500 cc/min.

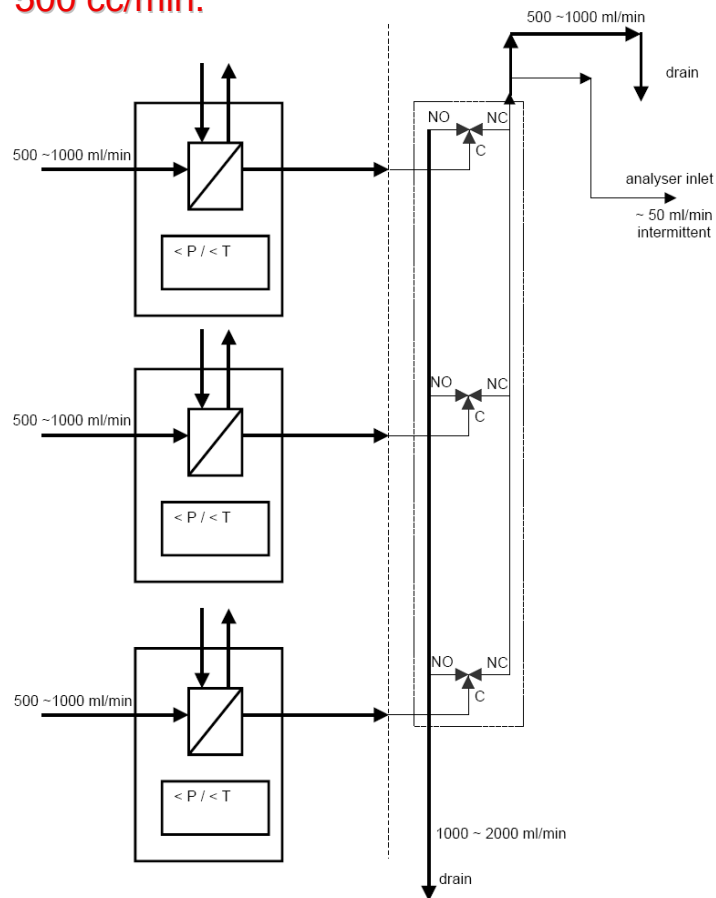

## Advantages:

- Low memory effects. All wetted parts are continuous flushed with a flow of ~500 ml/min.
- Closed system. No contamination by CO<sub>2</sub> from ambient.

## Disadvantages:

- Risk of sample leakage in the analyser.
- Sample should be delivered at constant conditions (flow/pressure)

**Diameter manifold bores and orifices typically > 4 mm**





## Stream selectors: 2-way valve system

Water Coolers  
500 cc/min.

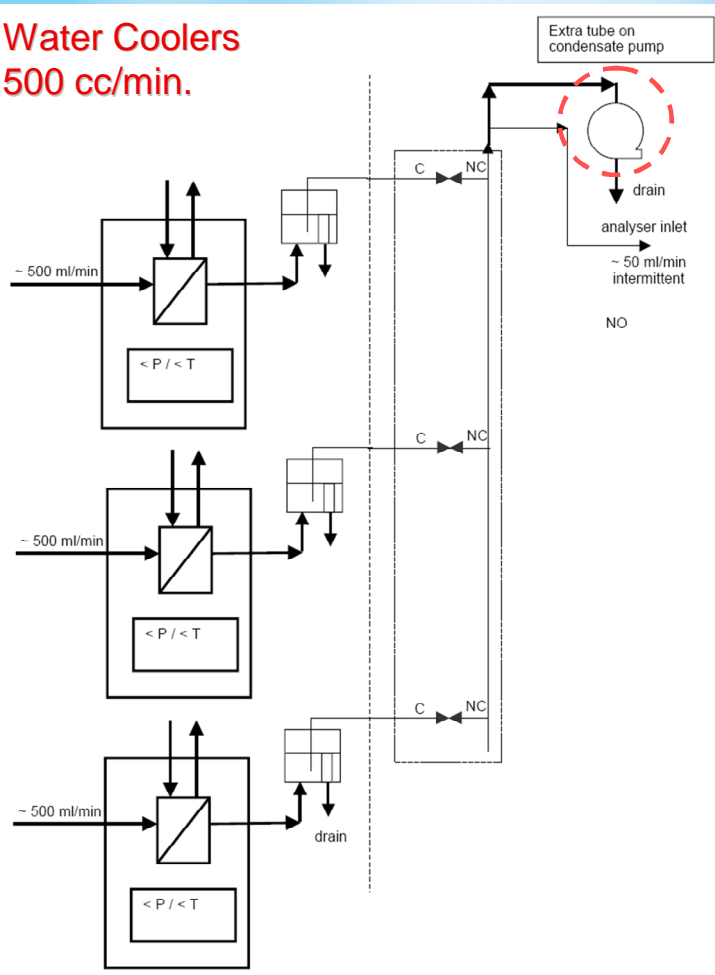

### Advantages:

- Reduced risk of leakage of sample into the analyser itself.
- If sample delivery is not constant (pressure dips) then still some buffer of sample in overflow cups.

### Disadvantages:

- Memory effects due to: dead volumes, independent sample tubes that are not continuous flushed, low flow trough the wetted parts (50 ml/min).

**Diameter manifold bores and orifices typically < 1,5 mm**





## Design & construction of the manifold

### Material of manifold and valves:

- Inert: PEEK, Teflon (FEP), Viton
- Can handle high temperatures and is chemical resistant

### 2-way valves (low flow):

- Small/no (dead) volumes,
- Bore holes < 1,5 mm
- Valve orifice < 1,5 mm

### 3-way valves (high volume):

- Avoid dead volumes
- Bore holes ~4 mm
- Valve orifices ~2 – 3 mm

Manifold location:  
integrated and as  
close as possible to  
the injection system

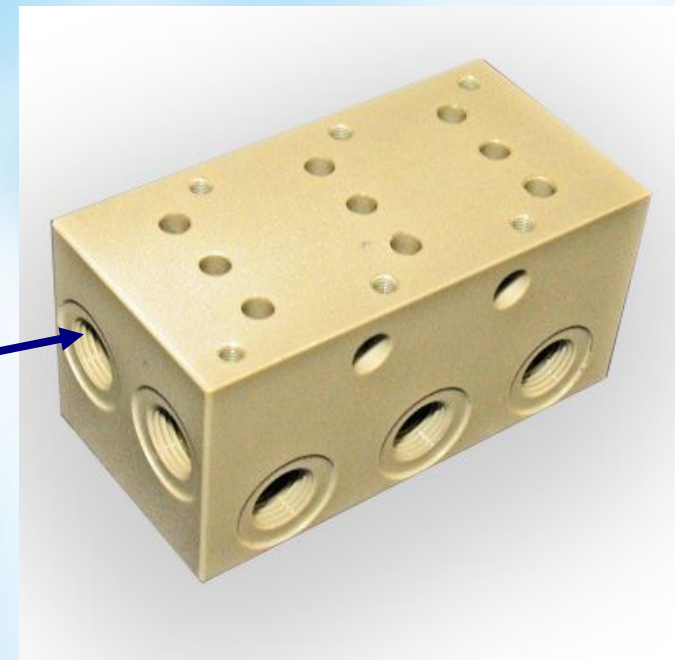



# Controller

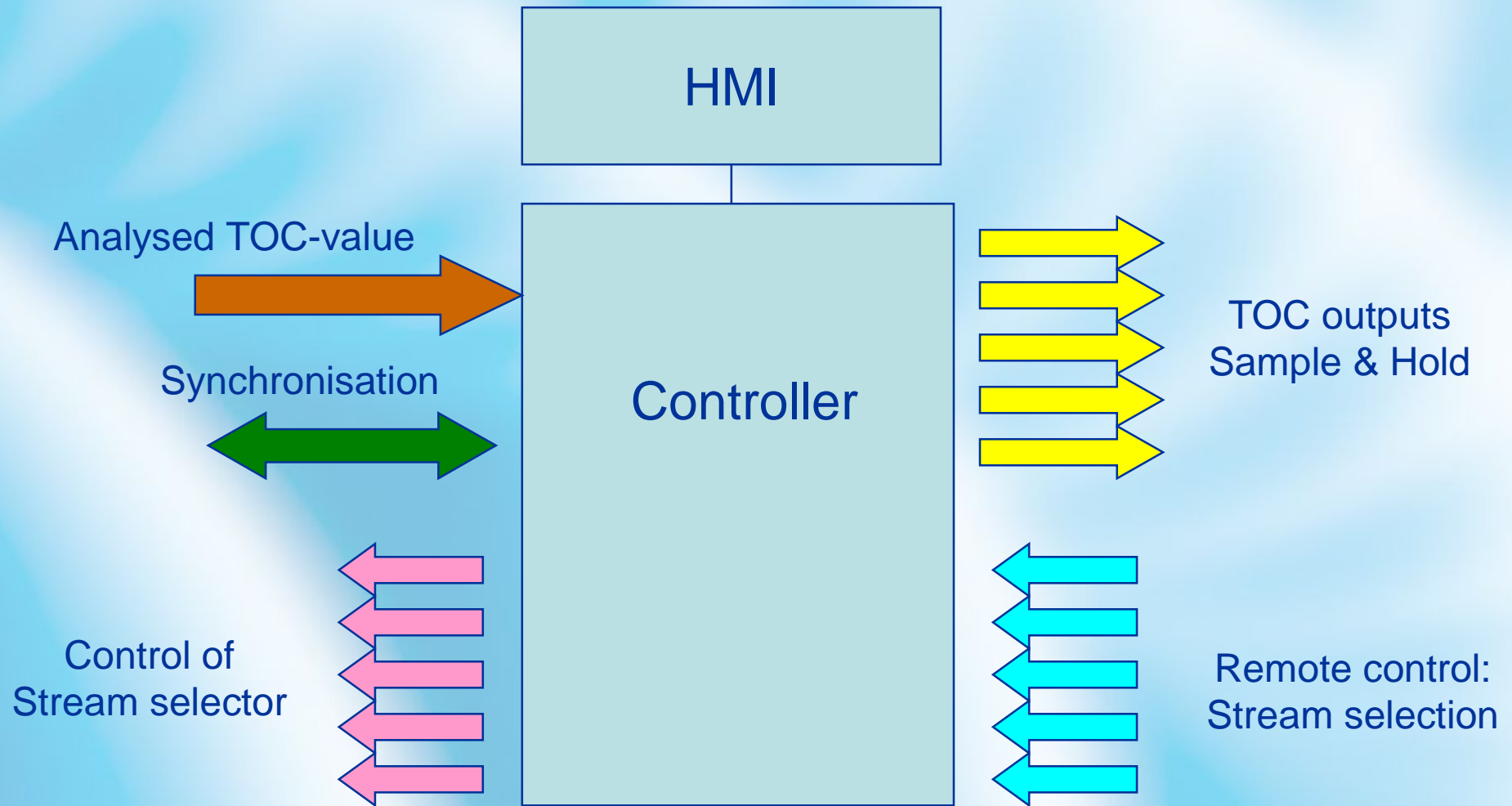



## Overflow cups & Flow alarms

### Design and construction:

#### Features:

- Temperature up to 70 degree Celsius
- Easy integration of standard capacitive level sensor
- Easy to mount a row of overflow cups on a panel

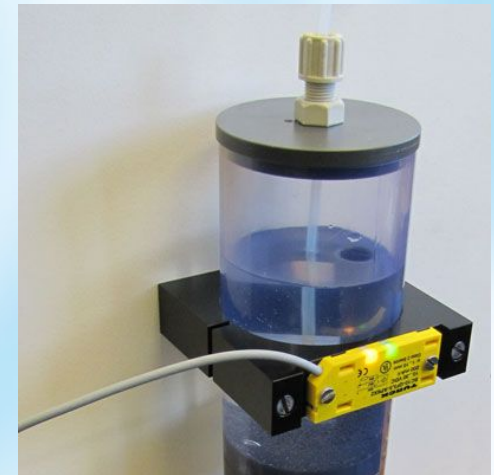



## Overflow cups & Flow alarms

### How it works:

- If there is no sample flow, then the analyser will slowly empty the overflow cup. The level sensor will alarm a too low level.
- The level will reach the alarm level after 1 to 5 analyses cycles (sample suction). This depends on the vertical mounting position of the cup in the holder/clamp.
- The advantage is that no false flow alarm will be generated when the sample flow fluctuates. This is an advantage versus a standard rota-flow meter with alarm indicator.

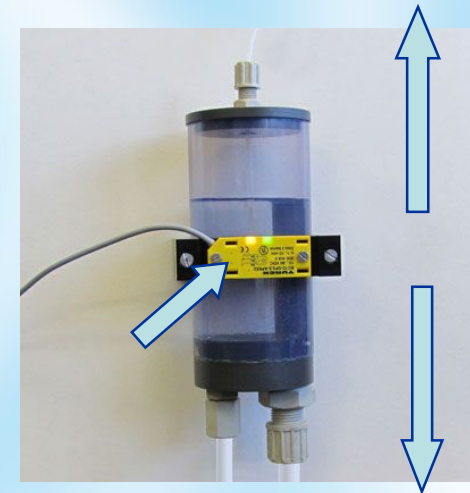



## How does that look like



Stream selector and manifold



Bottle for wet standard or grab sample

Inlet for gas validation



The display shows the stream being analysed and also the stream that are enabled.





## Thanks for your attention?



Back-up team ... the guy I'm looking for is always missing (12 or 13).





If any questions remain:

Contact:

ODS Sampling & Analytical Systems

[www.ods-analytical-systems.com](http://www.ods-analytical-systems.com) or

[www.ods-instrumentatie.nl](http://www.ods-instrumentatie.nl)

[www.ods-instrumentatie.be](http://www.ods-instrumentatie.be)

Phone: +31180640879

Send your enquiry to:

ODS BV

Department: Analytical Systems

P.O. Box 69

2990 AB Barendrecht

The Netherlands

