

EMCO Orifice Plate with Single Pressure Tapping Series MEF for Insertion Between Flanges

Principle

EMCO orifice plate are used as primary elements in flow measurement of liquid, gas and steam according to the differential pressure principle.

Construction

Design and calculation

Standards : ISO 5167, ASME MFC-3M, DIN 19205,
Shell Flow Meter Engineering Handbook,
L. K. Spink, AGA no. 3

Sizes : DN 50 - 1200, 2" - 42"

Pressure rating : PN 10 - 400, 150 - 2500 lbs

Plate thickness : 8 mm

Vent or drain hole : On request

Material : Carbon steel P265GH, AISI 316, 16Mo3,
13CrMo4-5, other materials on request.

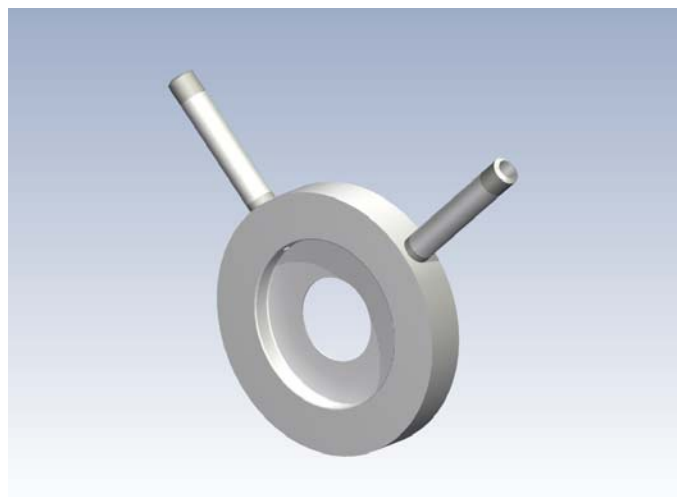

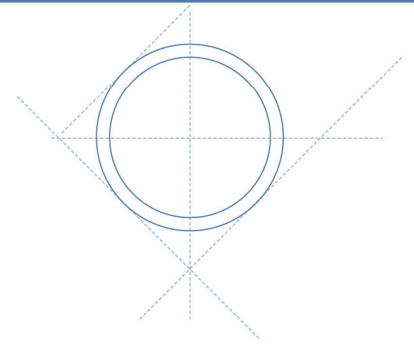

Mounting style : Between flanges with flat or raised face or groove according to DIN 2526, 2513, 2512, or RF according to B 6.5

Orifice plate shapes : Square edge concentric, square edge eccentric, conical, 1/4 circle, segment.
The plate is beveled on the down stream side except for 1/4 circle orifice plate.

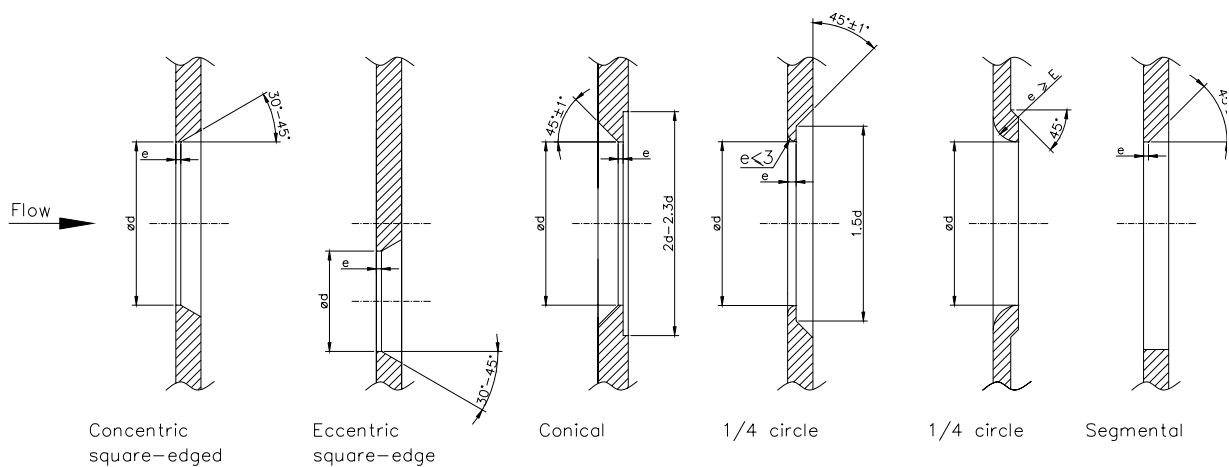

Pressure taps : 3/8", 1/2" BSP male, Ø 12 mm, 1/2" NPT

Tap lengths : 150 mm, others on request.

Tap location : At least 45 degrees apart
To be stated with order

Marking : The orifice plate is marked with "+" and "-" and flow direction.

Technical Data

Accuracy : +/- 0,6 % for $\beta < 0,6$ and equal to β for β values above 0,6

Pressure loss : Depending on β , for β equal to 0,6 : ca. 60 % of the differential pressure measured

Limits for Reynolds No : $Re > 1260 \times \beta^2 D$ according to ISO 5167
 $2000 < Re < 10^8$ according to ASME MFC-3M

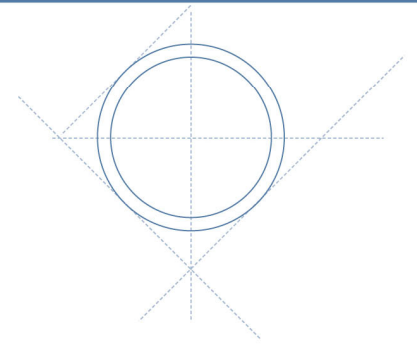

EMCO Orifice Plate Series MEF

Accessories : Shut-off valves and condensing chambers for steam flow measurement.
Flange assembly complete with bolts, nuts and gaskets.

Dimensions for DIN flanges

Size DN	Pipe OD	PN 10		PN 16		PN 25		PN 40		PN 64		PN 100		d1=
		D	d4	D	d4	D	d4	D	d4	D	d4	D	d4	D+
50	60.3	54.5	107	54.5	107	54.5	107	54.5	107	54.5	113	53.9	119	1
65	76.1	70.3	127	70.3	127	70.3	127	70.3	127	69.7	138	68.9	144	1
80	88.9	82.5	142	82.5	142	82.5	142	82.5	142	81.7	148	80.9	154	1
100	114.3	107.1	162	107.1	162	107.1	168	107.1	168	106.3	174	104.3	180	1
125	133.0	125.0	192	125.0	192	125.0	194	125.0	194	124.0	210	120.4	217	2
125	139.7	131.7	192	131.7	192	131.7	194	131.7	194	130.7	210	127.1	217	2
150	159.0	150.0	218	150.0	218	150.0	224	150.0	224	147.8	247	144.8	257	2
150	168.3	159.3	218	159.3	218	159.3	224	159.3	224	157.1	247	154.1	257	2
175	193.7	-	-	182.9	248	182.5	254	182.5	265	181.1	277	176.1	287	2
200	219.1	207.3	273	207.3	273	206.5	284	206.5	290	204.9	309	199.1	324	2
250	273.0	260.4	328	260.4	329	258.8	340	252.8	352	255.4	364	248.0	391	2
300	323.9	309.7	378	309.7	384	307.9	400	307.9	417	301.9	424	295.5	458	2
350	355.6	341.4	438	339.6	444	339.6	457	338.0	474	330.6	486	323.6	512	2
350	368.0	353.8	438	353.8	444	352.0	457	350.4	474	343.0	486	336.0	512	2
400	406.4	392.2	489	390.4	495	388.8	514	384.4	546	378.0	543	-	-	2
400	419.0	404.8	489	403.0	495	401.4	514	397.0	546	390.6	543	-	-	2
500	508.0	493.8	594	492.9	617	488.0	624	479.6	628	-	-	-	-	4
600	610.0	595.8	695	592.4	734	588.0	731	-	-	-	-	-	-	4
700	711.0	695.0	810	693.4	804	686.0	833	-	-	-	-	-	-	4
800	813.0	797.0	917	793.0	911	784.6	942	-	-	-	-	-	-	4
900	914.0	896.0	1017	894.0	1011	882.0	1042	-	-	-	-	-	-	4

All dimensions in mm

D : Inner pipe diameter

d4 : Outer diameter of carrier rings when mounted between flanges with facing according to DIN 2526.

d1 : Inner diameter plate holder. When mounted between flanges with facing according to DIN 2512 and 2513, the inner diameter is $D + 1.2$ mm.

