

FCI FlexSwitch® FLT® Series:

The Flow, Level, Interface and Temperature Switch

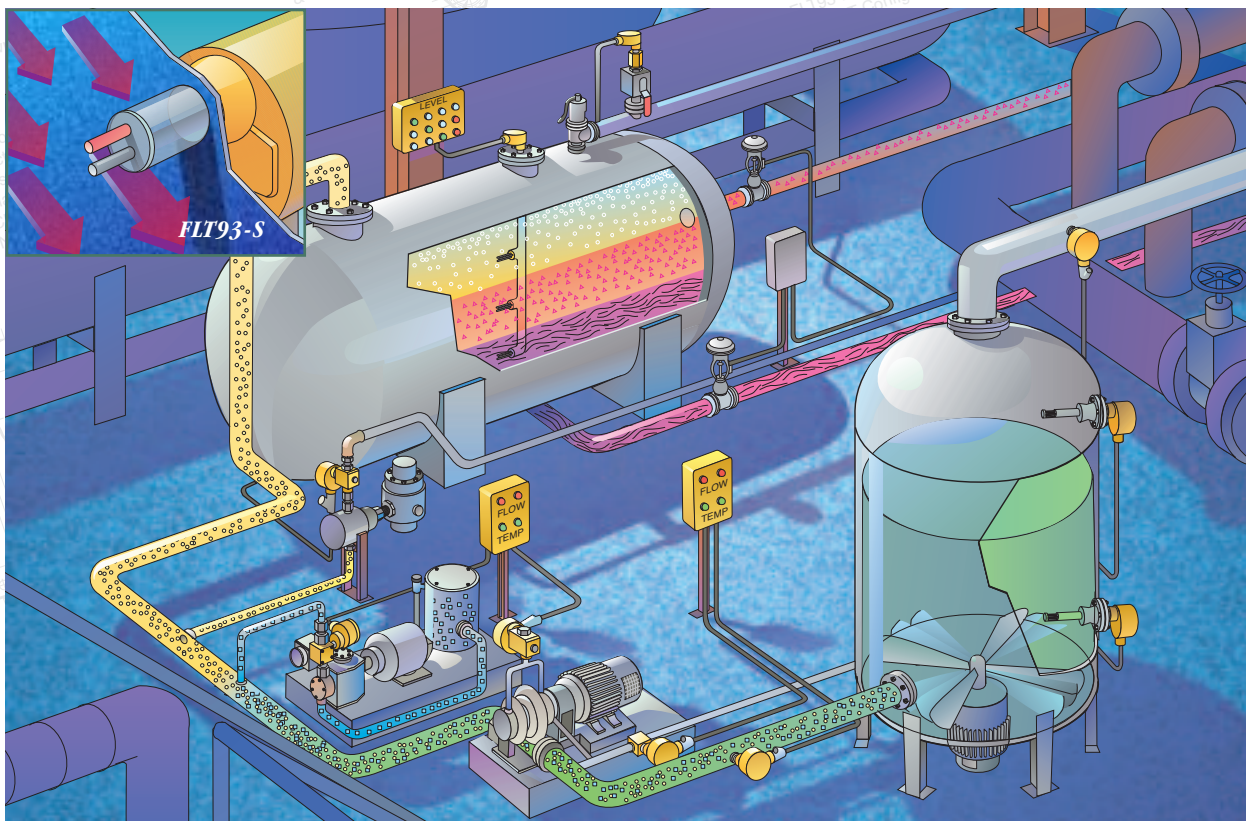

FCI FLT® SERIES

with Analog Outputs

and FlexSwitch Technology.

FCI FLUID COMPONENTS INTERNATIONAL LLC

The FLT[®]93 Series with FlexSwitch[®] Technology

FCI's FLT93 Series Switches with *FlexSwitch* technology represent the first true technological advance in flow, level, and temperature sensing and switching in over a decade. A single instrument, easily field-configured or factory preset, provides unparalleled accuracy, flexibility, and stability for most flow, level, and temperature sensing and switching needs.

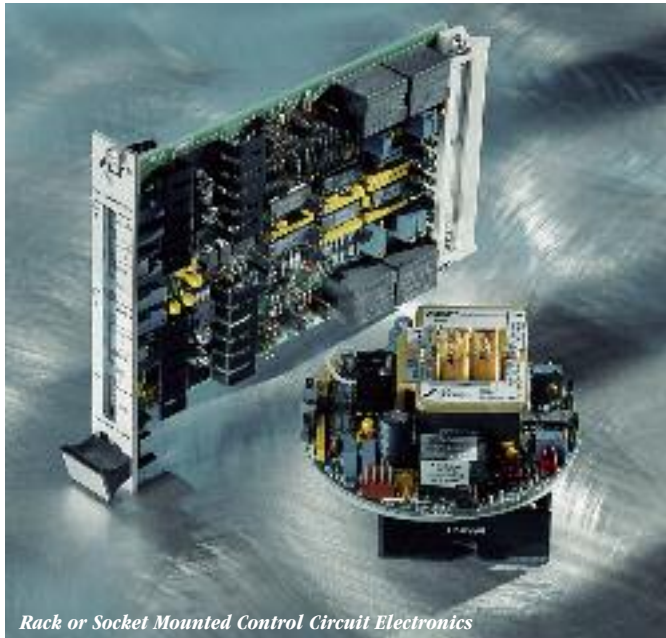

Rack or Socket Mounted Control Circuit Electronics

Standardization | This sensing and switching breakthrough is achieved in the FLT93 Series Switches by combining a new, highly accurate, all-welded sensing element with an advanced, user-friendly *FlexSwitch* control circuit.

Sensing Element. Two standard sensing element configurations are available to meet your most demanding application requirements. The FLT93-S is designed for use in standard heavy industrial applications and in applications with high velocity liquid setpoint requirements; the FLT93-F is designed for fast response gas applications. Both sensing elements can be supplied in either standard (-40° to +350°F [-40° to +177°C]) or medium (-100° to +500°F [-73° to +260°C]) temperature configurations. The FLT93-S is also available in a high temperature (-100° to +850°F [-73° to +454°C]) configuration.

Control Circuit. One standardized, field-configurable *FlexSwitch*

control circuit satisfies virtually any combination of application requirements. The *FlexSwitch* technology can be packaged to meet most integral, remote, and rack mounted configurations.

Precise Performance Accuracy | Leveraged from FCI's field-proven thermal dispersion experience, the unique sensor technology of the FLT93 Series Switches, combined with *FlexSwitch* temperature compensation circuitry, introduces unparalleled performance capabilities:

- › *Exclusive flow accuracy* as precise as $\pm 2\%$ of the setpoint velocity over a $\pm 50^\circ\text{F}$ [$\pm 28^\circ\text{C}$] temperature range; repeatability of $\pm 0.5\%$ reading.
- › *Level resolution* of ± 0.1 inch [± 0.5 cm]; repeatability of ± 0.05 inch [± 0.3 cm].
- › *Standard temperature accuracy* $\pm 2.0^\circ\text{F}$ [$\pm 1^\circ\text{C}$]; repeatability $\pm 1.0^\circ\text{F}$ [$\pm 0.6^\circ\text{C}$]. Improved temperature accuracy is available with factory calibration.

Integrated Technologies—Advanced FlexSwitch Circuitry

Available in both standard socket mount or optional rack mount configurations, FCI's fail-safe, dual alarm (SPDT) control circuit provides the FLT93 Series Switches with unmatched field flexibility and user-friendliness. The *FlexSwitch* control circuit also provides the exclusive advantage of one switch that offers the following field-selectable features:

- › Dual, independent SPDT relays for the following alarm combinations:
 - Flow rate and temperature
 - High flow and low flow
 - Point level and temperature
 - Flow rate and low liquid level
 - Three-phase level interface
 - Fail-safe flow, level, or temperature
- › One DPDT relay for single alarm of flow rate, liquid level or temperature is optionally selectable

Application Flexibility

Easy Field or Factory Preset Configurations. *FlexSwitch* circuit features are easily enabled and can be selected either in-situ or factory preset. Selections include the following:



FLT93-F and FLT93-S Sensing Elements

FLT93-S and FLT93-F Insertion FlexSwitch

Sensing Element Feature Highlights

- › No moving parts
- › All welded design
- › Exotic materials

FLT93-S

- › Designed for heavy industrial environments
- › High liquid flow rate sensitivity
- › High temperature service
- › Retractable packing glands

FLT93-F

- › Faster response
- › Small process connection

Control Circuit Feature Highlights

- › Temperature compensation
- › Analog output voltage for flow and temperature
- › Calibration mode switch to simulate alarm setpoint
- › Fail-safe setup
- › Dual alarm, each with SPDT relay/DPDT optional
- › Field selected input power



FLT93-C Sanitary Sensing Element

FLT93-C Sanitary Insertion FlexSwitch

Delivering the same field-tested performance and reliability as the FLT93-S and E, The FLT93-C is built to comply with the stringent 3A Sanitary and general sanitary requirements of the Food, Beverage, Pharmaceutical and Chemical industries.

The instrument's no moving parts design makes it ideal for monitoring the flow of syrups, fillings and other viscous media and product slurries. The FLT93-C is suitable for both clean-in-place and steam-in-place applications.

Control Circuit Feature Highlights

> Refer to FLT93-F and S on previous page

Common Applications

- > Pump protection
- > Additive verification
- > Gas/steam injection monitoring
- > Analyzer flow monitoring
- > Syrup flow monitoring
- > Low flow detection
- > Level/Interface

Flow Ranges for FLT93S, FLT93F, or FLT93C

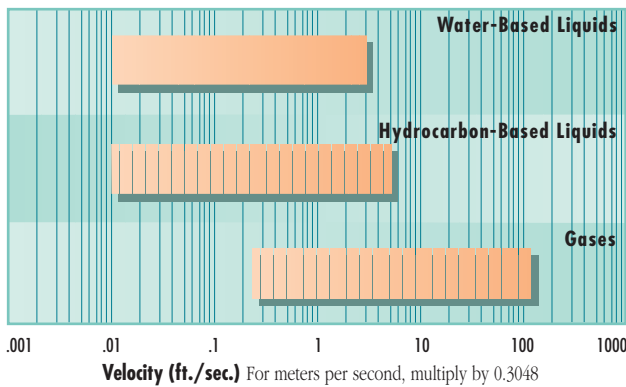

Typical Monitoring Applications

- > High/low pump flow
- > Relief valve and flare gas flow or leakage detection
- > HVAC flow monitoring
- > Monitoring heat exchanger and filter fouling
- > Drain line flow detection
- > Pump seal leak and lubricant detection
- > Wet/dry and sump seal detection
- > High/low level alarm and control
- > Interface control in separation vessels
- > High and low temperature alarm

Typical Level and Interface Output Signals

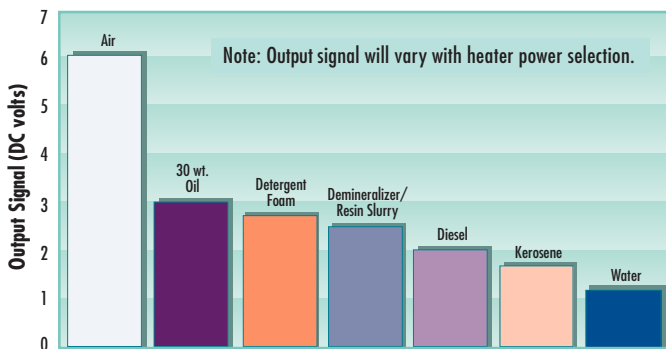

Typical Liquid Flow Curves

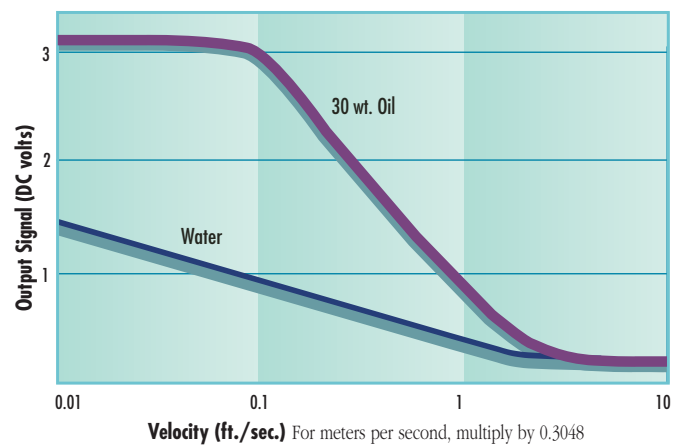

Accuracy and Temperature Compensation | FLT93 Series switches are “precision temperature compensated” to insure the accuracy of factory and field set alarms when installed in dynamic process applications. Accuracy combined with temperature compensation results in:

- > Preventing false alarms or alarm failure
- > Maximizing operator and process safety
- > Having the option to set alarms within a narrow set point range

The “Temperature Compensated Flow Curves” graph (right) illustrates how “temperature compensated” flow switches will not experience signal drift during temperature changes. Whereas a “non-temperature compensated” flow switch experiences signal drift (as indicated by the red arrow) causing alarm failure.

Temperature Compensated Flow Curves

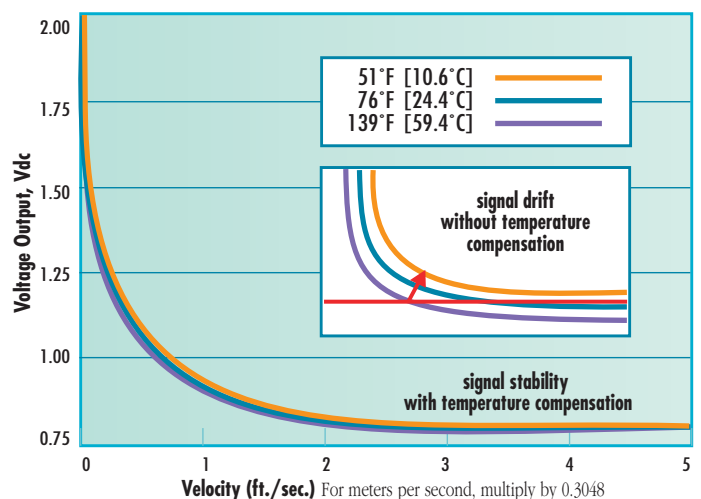

Field Selectable Feature Advantage/Benefit

Input Power Jumpers Maximizes voltage source flexibility and emergency power operations.

Application/Heater Power Selection Jumpers Optimizes signal level or best configuration for changing application conditions.

Relay Configuration and Logic Jumpers Enables easy field selection of SPDT or DPDT configurations and relay energization modes.

Calibrate/Operate Mode Selects field verification, pre-check, calibration or general operation modes.

Maximized Instrument Life Simple reconfiguration allows the instrument to be further utilized in new service applications or easily adjusted as specific application requirements change.

Simple, Accurate, Field Set Alarms Field calibrations and setpoint adjustments are easily performed. Voltage readings at critical setpoint values can easily be recorded for reference purposes or for optimized monitoring.

Field Selectable Input Power The FLT93 Series' *FlexSwitch* circuit is field configurable for compatibility with the most common electrical power. Selection of 24 Vdc, 115 Vac or 230 Vac by simple jumper selection is a standard feature.

5294 Control Circuit Functional Diagram

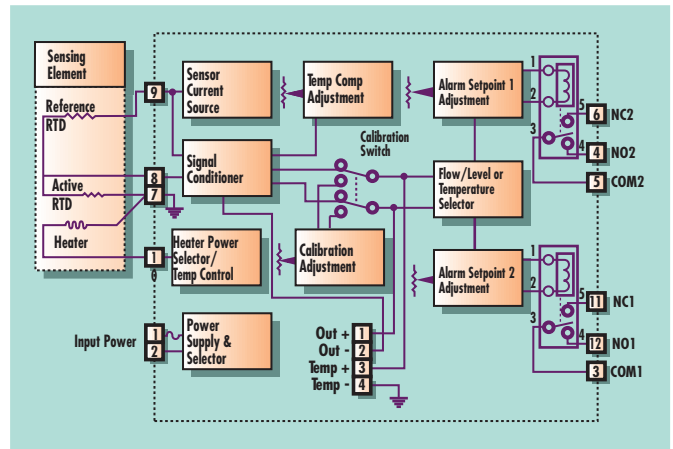

Operation Verification and/or Pre-Check Alarm setpoint and fail-safe verification is easily performed before installation or in-situ. The dual alarms are field-configured to fail-safe when used exclusively for flow rate, liquid level, or temperature alarm. Resulting from FCI's historically proven durability, pre-check capability and fail-safe operation, operators will be protected from any unforeseen failure. This combination of features gives the FLT Series Switches unrivaled reliability. Setpoints may be configured to provide failure information of sensing element assembly as well as control circuit electronic failure.

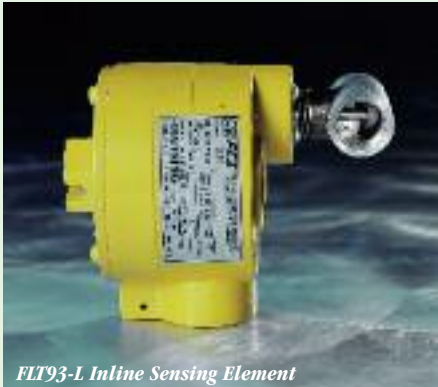

FLT93-L Inline Sensing Element

FLT93-L Inline FlexSwitch

Sensing Element Feature Highlights

- > Ideal for extremely low flow (down to .015 cc/sec)
- > 316L stainless steel or Hastelloy C-276 wetted parts, all welded.
- > Process temperatures to 500°F [+260°C]
- > Process pressures to 2000 psig [138 bar(g)]
- > Temperature compensation results in accurate and stable setpoints and output signals.
- > Hazardous location system approvals: FM, CSA, CENELEC, CE Mark and CRN.

Control Circuit Feature Highlights

- > Refer to FLT93-F and S on previous page

Common Applications

- > Chemical additive verification
- > Coolant and lubrication seal leakage
- > Lube flow detection
- > Seal water flow
- > Analyzer flow detector
- > Air flow purge monitoring
- > Spray nozzle monitoring

Setpoint Adjustment Ranges for Typical Media

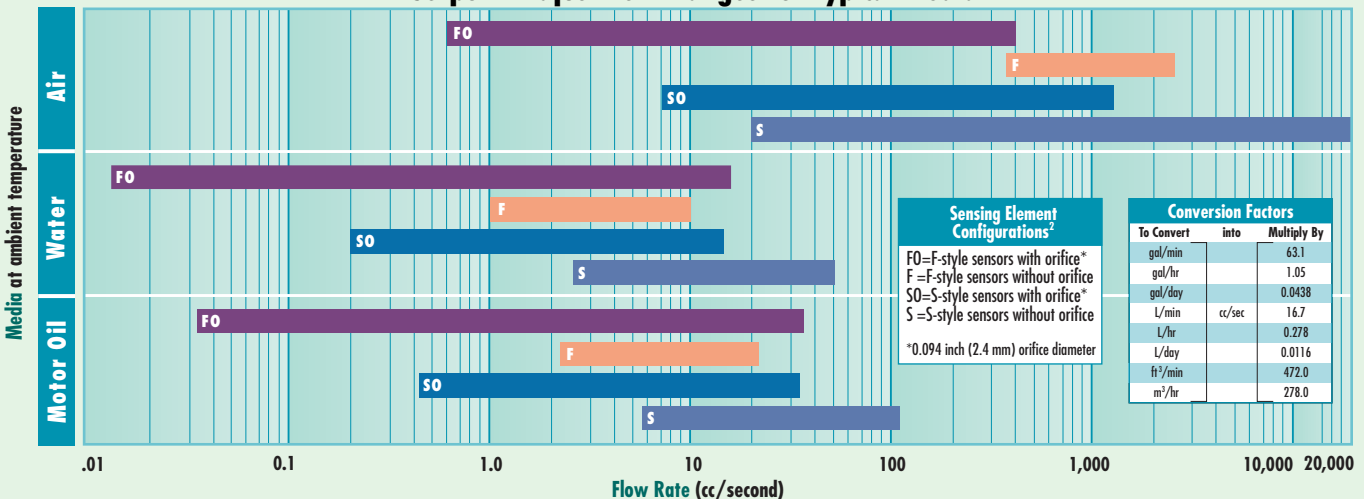

Sensing Element Configurations*
 FO=F-style sensors with orifice*
 F=F-style sensors without orifice
 SO=S-style sensors with orifice*
 S=S-style sensors without orifice
 *0.094 inch (2.4 mm) orifice diameter

To Convert	into	Multiply By
gal/min		63.1
gal/hr		1.05
gal/day		0.0438
L/min	cc/sec	16.7
L/hr		0.278
L/day		0.0116
ft ³ /min		472.0
m ³ /hr		278.0

FlexSwitch FLT93 Series General Specifications

Application

Flow rate and /or level/interface and temperature sensing in liquid, gas and slurry applications.

Sensing Elements

> Process Connection

Models S and F

3/4 inch male NPT standard; optional 1 inch BSP, 1 inch male NPT, 3/4 inch Male NPT (FLT93-F only); flanges, spool pieces, sanitary fittings or retractable sensing element optional.

Model L

1 inch male NPT or 3/4 inch female NPT, both ends with orifice; flanges optional.

Model C

Sanitary flange

> Insertion Length

Models S and F

Available in standard lengths of 1.2 inch [30 mm], 2 inches [51 mm], 4 inches [102 mm], 6 inches [152 mm], 9 inches [229 mm], 12 inches [305 mm], 18 inches [457 mm] and custom-specified lengths.

Model L

3.375 inch [86 mm] in-line body length

Model C

Please see chart on outline dimensional.

> Sensing Element

Models S and F

All wetted surfaces are 316L stainless steel with all-welded construction. Hastelloy C, Monel 400, electro-polished stainless steel and titanium (FLT93-S only) are optionally available. Other spray coatings are available on special request (i.e., tantalum, chromium carbide).

Model L

All wetted surfaces are 316L stainless steel with all-welded construction. Hastelloy C, Monel 400 and titanium are optionally available.

Model C

All wetted surfaces are 316L stainless steel with all-welded construction electro-polished to 20 Ra.

> Operating Temperature

Sensing Element:

All Models

Standard temperature configuration:

-40° to +350°F [-40° to +177°C]

Medium temperature configuration:

-100° to +500°F [-73° to +260°C]

Model S Only

High temperature configuration:

-100° to +850°F [-73° to +454°C]

Control Circuit:

All Models

Ambient -40° to +140°F [-40° + 60°C]

> Operating Pressure

Models S, F and L

Hydrostatically proof pressure tested to 3500 psig [241 bar(g)] at 70°F [21°C]. Derated with temperature, the maximum recommended operation service is 2350 psig [162 bar(g)] at 500°F [260°C].

Model C

To 2000 psig [138 bar(g)]

Higher ratings available with special construction and test certification.

Control Circuit Features

> Control Circuit

Available in both standard socket mount, single channel, dual alarm, epoxy sealed relays and in rack mounted configurations (card cage or enclosure not included).

> Output Signal

Analog DC voltage related to flow or level/interface signal and proportional to temperature, standard.

> Input Power

Field selected or pre-configured in the factory to 115 Vac (± 15), 230 Vac (± 30 , 50 to 60 Hz), 24 Vdc (+4, -3) or 24 Vac (+2, -6); 100 Vac ± 10 optionally available. LED indicates power on.

> Power Consumption

AC units, 13 VA maximum; DC units, 7 watts maximum.

> Heater Power

Field or factory selected to optimize switching performance and rangeability and selectable for specific fluid service requirements. 7 watts power consumption, 230 mA maximum.

Typical Service	Sensing Element	Power (W)
Gas or Air	S-Style	0.75
	F-Style	0.25
Liquids	S-Style	3.0

The above typical service power selections are for reference only. Depending on application requirements, surface temperature rating requirements, and rangeability expectations, alternate power selections may be recommended. Other intermediate power selections can be made. Consult installation manual for recommendations in your service.

> Relay Rating

Dual SPDT or single DPDT field configurable 6 amp resistive at 115 Vac, 240 Vac or 24 Vdc; hermetically sealed relay configurations optionally available.

> Electrical Enclosure

Aluminum (epoxy coated) or optional stainless steel. Enclosures are rated for hazardous location use (Class I and II, Division 1 and 2, Group B, C, D, E, F and G; and EEx d IIC) and resists the effect of weather and corrosion (NEMA and CSA Type 4X and equivalent to IP66).

[specifications continued on next page]

FlexSwitch FLT93 Series General Specifications [continued]

For Flow Service

> Setpoint Range

Model S

Water-based Liquids:

0.01 to 0.5 FPS [0.003 to 0.15 MPS] with 0.75 watt heater;

0.01 to 3.0 FPS [0.003 to 0.9 MPS] with 3.0 watt heater.

Hydrocarbon-based Liquids:

0.01 to 1.0 FPS [0.003 to 0.3 MPS] with 0.75 watt heater;

0.01 to 5.0 FPS with [0.003 to 1.5 MPS] with 3.0 watt heater.

Air/Gas:

0.25 to 120 SFPS [0.08 to 37 NMPS] with 0.75 watt heater at standard conditions; 70°F [21.1°C], 14.7 psia [1.013 bar(g)].

Other Fluids: Contact the factory for approximate rangeability.

Model F

Air/Gas:

0.25 to 120 SFPS [0.08 to 37 NMPS] 0.75 watt heater at standard conditions; 70°F [21.1°C], 14.7 psig [1.013 bar(g)].

Model L

Water-based Liquids: 0.015 to 50 cc/sec

Hydrocarbon-based Liquids: 0.033 to 110 cc/sec

Air/Gas: 0.6 to 20,000 cc/sec

Model C

Water-based Liquids: 0.01 to 3.0 FPS [0.003 to 0.9 MPS]

Syrup: to 5.0 FPS [0.003 to 1.5 MPS]

Air/Gas: 0.25 to 120 SFPS [0.08 to 36.6 NMPS]

> Factory Calibrated Switch Point Accuracy

Any flow rate within the instrument flow range may be selected as a setpoint alarm. A factory-calibrated setpoint adjustment may be optimally preset with accuracy of $\pm 2\%$ of setpoint velocity over an operating temperature range of $\pm 50^\circ\text{F}$ [$\pm 28^\circ\text{C}$].

> Monitoring Accuracy

Based on a measured output voltage over the entire flow range, an operating temperature range of $\pm 50^\circ\text{F}$ [$\pm 28^\circ\text{C}$], and an operating pressure range of ± 100 psig [± 7 bar(g)]:

Liquids: $\pm 5\%$ reading or ± 0.04 SFPS [± 0.012 NMPS], whichever is larger

Gases: $\pm 5\%$ reading or ± 2 SFPS [± 0.06 NMPS], whichever is larger

> Repeatability

$\pm 0.5\%$ reading

For Level/Interface Service

> Accuracy

Model S

± 0.25 inch [± 6.4 mm]

Model F

± 0.1 inch [± 2.5 mm]

> Repeatability

Model S

± 0.125 inch [± 3.2 mm]

Model F

± 0.05 inch [± 1.3 mm]

For Temperature Service

> Accuracy

$\pm 2.0^\circ\text{F}$ [$\pm 1^\circ\text{C}$] with field setpoint adjustment. Monitoring accuracy $\pm 3.5^\circ\text{F}$ [$\pm 2^\circ\text{C}$] with standard curve fit output voltage operation across the selected instrument temperature range. Higher accuracy available with factory calibrations.

> Repeatability

$\pm 1.0^\circ\text{F}$ [$\pm 0.6^\circ\text{C}$]

The above accuracy is based on liquid or slurry service and in gas service with a minimum 1 sfps (0.3 nmfs) velocity past the sensing element or with the heater deactivated for temperature sensing service only.

Factory Application-Specific Set-up and Setpoint Calibration

Standard instrument factory default setting, unless otherwise selected at order entry, will be as follows:

- > 115 Vac input power for all FM Approved units. 230 Vac for all other agency approval units.
- > Dual SPDT alarms set for:
 - Alarm No. 1:** Preset for flow or level and to de-energize with decreasing conditions.
 - Alarm No. 2:** Preset to de-energize for increasing temperature at 10°F [5°C] below the maximum instrument process temperature.
- > Heater power at 0.25 watt on Model F or 0.75 watt on Model S.
- > Calibration switch set at "operate".

Factory calibration including set-up for specific service, process fluid and alarm conditions optionally available. Contact factory for fluid handling capabilities.

Agency Approvals

FM, CSA, CENELEC,
T4 Rated (System approval),
ATEX, CE Mark and CRN
IEC Ex d IIC

(SIL) 2 Compliant

Shipping Weight (approximate)

Integral: 8 lbs. [3.6 kgs]

Remote: 13 lbs. [5.9 kgs]

FLT93-S and FLT93-F FlexSwitch, Insertion

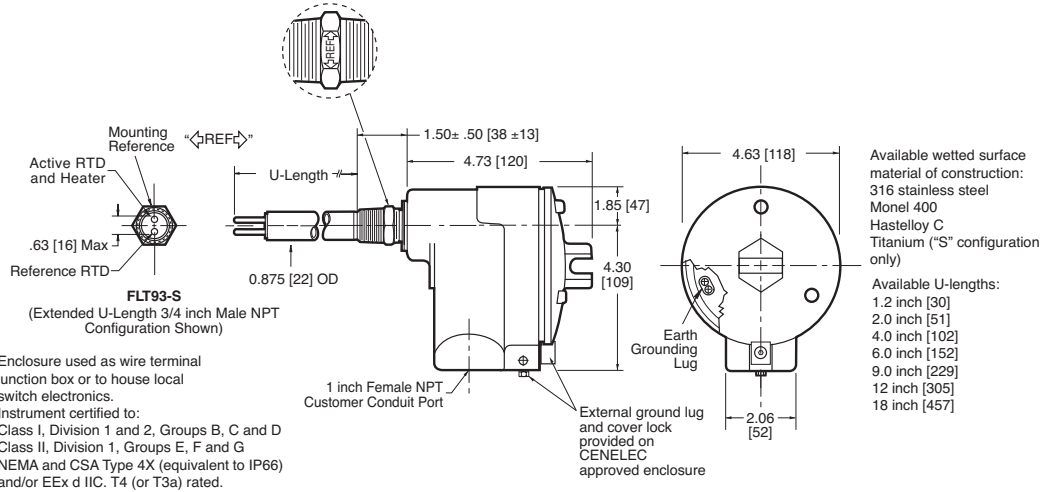

FLT93-L FlexSwitch, Inline

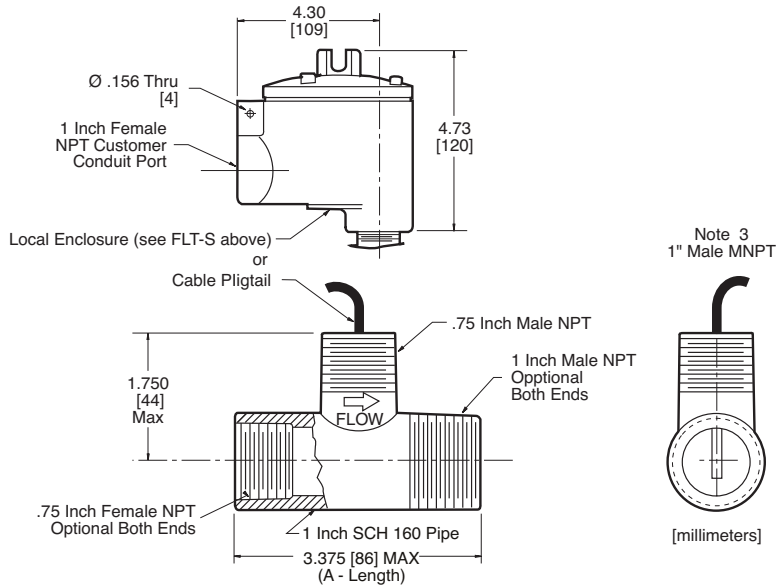

Notes:

1. For best performance, the sensing element should be installed into a vertical section of pipe. Liquids should flow up through the sensing element and gases should flow down through the sensing element.
2. The time response of the F-style sensors is faster than the S-style sensors. However, the S-style sensors can withstand higher fluid forces (drag) than the F-style sensors.
3. Refer to the FlexSwitch product brochure (Doc. No. 02MK011288) for additional information and complete specifications.
4. Use the Model FLT93L Ordering Information Sheet (OIS Doc. No. 01SA011426) to configure the complete instrument part number.
5. Sensing element A-length is 12.0 inches (305 mm) if flanges are specified for the process connection.

Other end connections available.

FLT93-C FlexSwitch, Sanitary Insertion

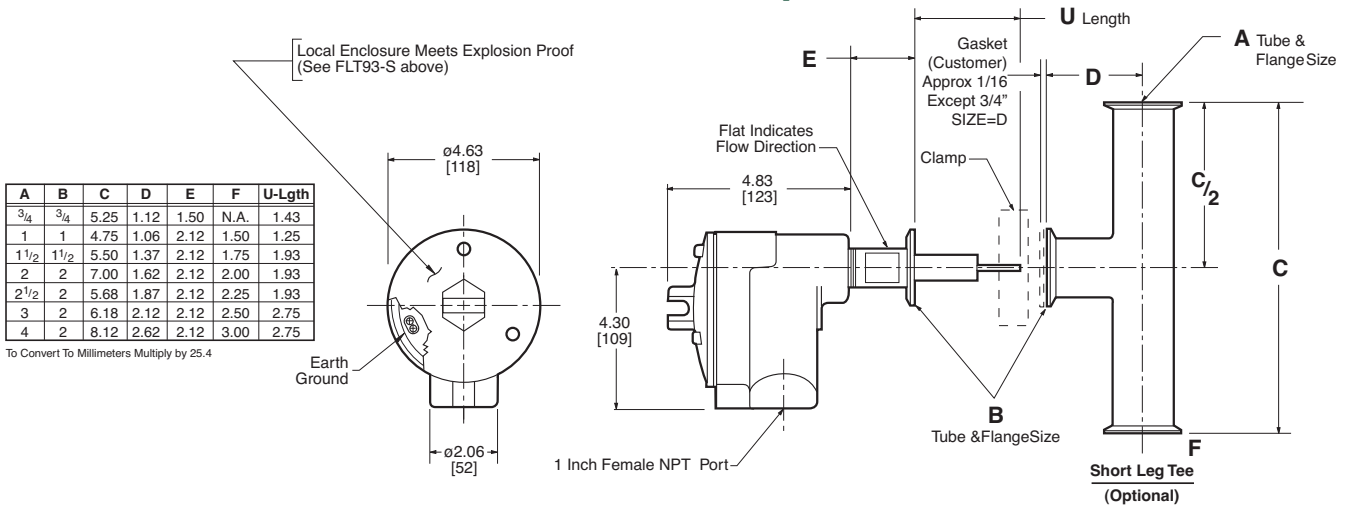



Test and Calibration Laboratory | Fluid Components International maintains an extensive, instrument test and calibration laboratory at its headquarters in San Marcos, California. Utilizing the latest in advanced, computerized data acquisition systems and calibration test equipment, this facility permits comprehensive product development, testing, and calibration. Any FCI product can be calibrated in accordance with customer specifications. Laboratory standards are maintained with NIST (National Institute of Standards and Technology) traceable Cavitating Venturis (CVs) and precisely calibrated, pressure and temperature corrected turbine flowmeters.

Combustible and non-combustible gas calibration flow stands allow for the calibration of FCI products in a wide range of gases and gas mixtures in flow stand line sizes as small as 1/8 inch to 30 inches [3 to 760 mm] in diameter. A variety of flow profiles

from laminar to turbulent conditions are generated to duplicate actual field conditions. Flow rates from 0 to 20,000+ SCFM [0 to 34,000 NCMH], velocities from 0 to 800 SFPS [0 to 240 NMPS], pressures from vacuum to 3000 psig [200 bar(g)], and temperatures from -100° to +900°F [-70° to +480°C] are available.

On-Site Calibration and Training | In-situ calibration is available from FCI's Field Service engineers where precise test and calibration is accomplished in actual media conditions.

FCI's Training Department can provide on-site or at the factory Product Knowledge Workshops for our customers. The workshops cover installation, setup, and troubleshooting skills, and include hands-on exercises using real products, under actual operating conditions.

24 Hour Customer Service Access Available

FCI FLUID COMPONENTS
INTERNATIONAL LLC

NIST Net

Web: www.fluidcomponents.com

1755 La Costa Meadows Drive, San Marcos, California 92078 USA | **Phone:** 760-744-6950 | **Toll free:** 800-854-1993 | **Fax:** 760-736-6250

European Office: Persephonestraat 3-01 5047 TT Tilburg, The Netherlands | **Phone:** 31-13-5159989 | **Fax:** 31-13-5799036

ISO 9001:2000 and AS9100 certified