



Turbine Meter





Table of Contents

Applications of the Turbine Meter RQ Series	Page 3
Type RQ for Liquids	Page 4
RQ Turbine Meter with UST Universal Transmitter	Page 7
RQ Turbine Meter with AG 81, AG 82, AG 83	Page 8
Turbine Meter Profile	Page 10





Applications of the Turbine Meter RQ Series

The turbine meter is used for flow and volume measurement of liquid media such as:

- crude oils
- mineral oils
- acids
- alkaline solutions
- solvents
- water
- liquefied gases

RQ series turbine flow meters are built with nominal size of 10 to 300 mm. Depending on the nominal size, they can be employed from PN 6 to PN 320. The maximum allowable operating temperature of the material being measured can, depending on the model, reach 250°C.

Turbine meter RQ in a system for measurement of liquefied gas

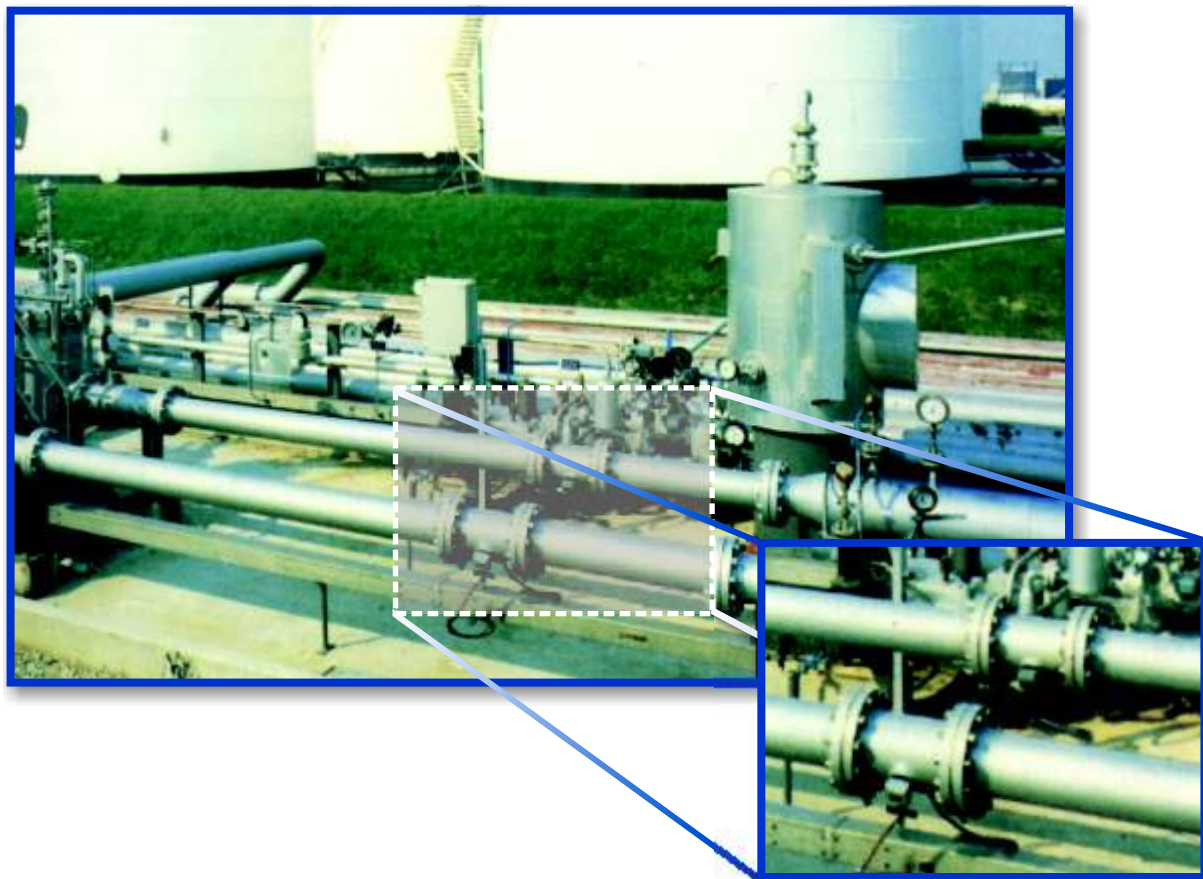



Type RQ for Liquids

General

- Proven, reliable measurement system
- Approved by local bureau of standards
- High measuring accuracy
- High reproducibility
- Large flows
- Inductive pulse pick up
- Can be used for high operating overpressures, High operating temperatures and low viscosities



Measuring Principle

The turbine meter is an indirect volume meter. It essentially consists of a freely rotating axial turbine wheel in a liquid flow.

The turbine wheel is rotated by the liquid and spins at a rotational speed, which corresponds to the average flow velocity of the liquid in the free cross section of the turbine flow meter. The rotational speed of the turbine wheel is thus proportional to the volumetric flow and the number of revolutions is proportional to the volume, which flows through.

The rotational movement is transmitted through the casing wall in a noninteracting manner to the outside by means of magnetic-inductive pulse pick up. A pick up mounted outside of the casing is used for this purpose. An electromagnetic field is generated with a coil located in the scanning head.

RQ with UST



Ferromagnetic components move through this field and induce electrical voltage. The ferromagnetic components consist, depending on the series of the turbine meter, of the turbine wheel blades or pins, which are arranged around the cover band of the turbine wheel.

Per blade or pin an electrical voltage pulse is produced, which corresponds to a certain volume. This value is the meter factor K (pulse/volume unit). A preamplifier amplifies and transforms the voltage pulse into a square-wave signal corresponding to NAMUR, which allows secure transmission at up to 1000 meters.

Principle of the Pulse Pick-up

- 1 Turbine wheel with ferromagnetic blades
- 2 Turbine wheel with cover band
- 3 Ferromagnetic pin
- 4 Cover band
- 5 Turbine flow meter casing
- 6 Ferromagnetic pin
- 7 Coil
- 8 Permanent magnet
- 9 Preamplifier

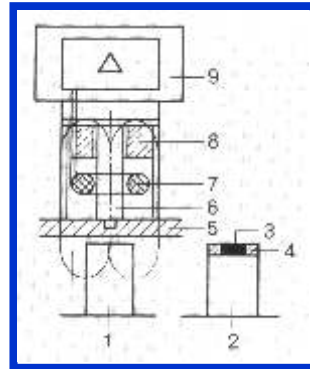

Series

The RQ turbine flow meters are available in two series.

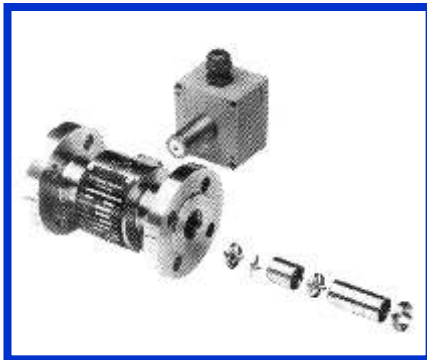

Series 1 DN 10 to 65

For the 1 series, the measuring element can be checked and mounted as a unit. You can replace the element without rechecking the meter.



Series 2 DN 80 to 300

Series 2 contains a turbine wheel with a cover band and inserted pins. This provides a higher pulse resolution.

Turbine Flow Meter Materials

Series	Material Group	Temperature of Material being Measured (°C)	Nominal Pressure	Housing	Turbine Wheel	Materials		
						Inner Parts	Bearing	Bearing Axle
1	FS/FG	-196...+250	PN 6...250 Class 150...1500	1.4429	1.4460/ 1.4462	1.4571 1.4580	Saphir Kohle	Wolfram- Karbid
2	F 2	-10...+250	PN 10...100 Class 150...600	1.0619.01 1.0460	DN 80 = 1.4571/1.4462 3 DN 100 = 1.4571	1.4571 1.4581	Wolfram- Karbid	Wolfram- Karbid
	F 5		PN 6...PN 100 Class 150...600	1.4408 1.4571				

Special materials upon request.



Series 1

Size		Flowrate	Meter Factor	Frequency	Pulses per revolution	Flowrange [% von Q _{max}]	Accuracy (meter with inlet section) [%] depending on viscosity [m Pa s]				
DN	ANSI	Q _{max} [m ³ /h]	Imp/dm ³	f _{max} [Hz]			0,2 - 2	2 - 6	6 - 10	10 - 20	20 - 50
10	-	1,5	1750	730	4	10 ... 100	± 0,3	± 1,0	± 2,1	± 3,4	± 6,5
						20 ... 100		± 0,6	± 0,8	± 2,0	± 4,0
15	½	6	310	517		10 ... 100	± 0,3	± 1,0	± 2,1	± 3,4	± 6,5
						20 ... 100		± 0,6	± 0,8	± 2,0	± 4,0
20	¾	12	170	567		10 ... 100	± 0,3	± 0,9	± 1,5	± 1,8	± 2,4
						20 ... 100		± 0,5		± 0,7	± 1,6
25	1	18	105	525		10 ... 100	± 0,3	± 0,7	± 1,3	± 1,8	± 2,4
						20 ... 100		± 0,4	± 0,5	± 0,7	± 1,5
32	1¼	30	58	467		10 ... 100	± 0,3	± 0,5	± 1,3	± 1,7	± 2,2
						20 ... 100		± 0,3	± 0,4	± 0,7	± 1,3
40	1½	42	22	257		10 ... 100	± 0,3	± 0,3	± 0,9	± 1,3	± 1,9
						20 ... 100		± 0,4		± 0,5	± 0,9
50	2	72	12,4	248		10 ... 100	± 0,3	± 0,4	± 0,8	± 1,2	± 1,5
						20 ... 100		± 0,3		± 0,4	± 0,8
65	2½	120	6	200		10 ... 100	± 0,3	± 0,4	± 0,5	± 0,9	± 1,4
						20 ... 100		± 0,3		± 0,4	± 0,8

Series 2

Size		Flowrate	Meter Factor	Frequency	Pulses per revolution	Flowrange [% von Q _{max}]	Accuracy (meter with inlet section) [%] depending on viscosity [m Pa s]					
DN	ANSI	Q _{max} [m ³ /h]	Imp/dm ³	f _{max} [Hz]			0,2 - 0,7	0,7 - 2	2 - 6	6 - 10	10 - 50	
80	3	180	15	750	12	10 ... 100	± 0,3				± 0,5	± 1,2
						20 ... 100	± 0,3				± 0,3	± 0,5
100	4	300	6	500	10	10 ... 100	± 0,3				± 0,3	± 0,5
						20 ... 100	± 0,2	± 0,4	± 0,3	± 0,5		
150	6	600	3,4	567	18	10 ... 100	± 0,2	± 0,3			± 0,4	
						20 ... 100	± 0,3				± 0,2	
200	8	1200	1,84	613	24	10 ... 100	± 0,2	± 0,3	± 0,3	± 0,3	± 0,4	
						20 ... 100	± 0,2				± 0,3	
250	10	1800	1,24	600	40	10 ... 100	± 0,2				± 0,3	
						20 ... 100	± 0,2				± 0,3	
300	12	2400	0,78	520	44	10 ... 100	± 0,2				± 0,3	
						20 ... 100	± 0,2	± 0,3			± 0,3	

Operating Conditions

Minimum operating overpressure:

And Δp_{RQ} is:

P_v is:

$$p_{min} \geq 2 \times \Delta p_{RQ} + 1.25 p_v \text{ [bar]}$$

Pressure loss of the turbine flow meter

The vapor pressure of the liquid being measured

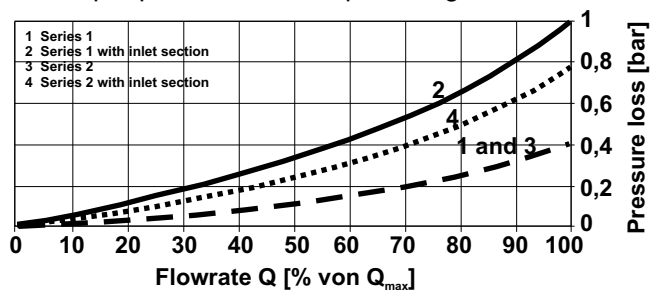

Installation position:

Inlet and outlet sections:

Filter:

Gas and air separator:

Series 1 horizontal, Series 2 horizontal

The lengths shown in the table on page 9 are to be maintained.

For custody transfer (fiscal metering), these are prescribed and obligatory. When calibrating the meter at the manufacturing plant, these inlet and outlets sections are to be included.

To protect the meter against damage from solids in the liquid flow, a filter is to be mounted in front of the meter with a maximum mesh width of 1 mm.

Inclusion of air or gas can lead to overtorque and thus to the destruction of the measuring element. The use of a gas and air separator is therefore urgently recommended.

RQ Turbine Flow Meter with UST Universal Transmitter

With the proven turbine flow meter as the measuring principle

- Direct recording of the volume and the volumetric flow
- Long service life and reliability
- Measurement with low viscosities, for example, liquefied gas
- Measurement of non-conductive liquids, in particular, hydrocarbons is possible
- Highest measuring accuracy and reproducibility
- Low influence of flow velocity profile and viscosity due to optimized design
- No zero point drift
- Low pressure loss of max. 0.4 bars for Q_{max} .

Also includes modern communications electronics

- High resolution pick-up system without moving parts
- Two wire technology
- 4-20 mA output or pulse output with additional pulse output acc. NAMUR
- With local display
- Display is user friendly due to the specially developed software, SensorPort, and easy to use
- With HART® protocol
- Operation with hand-held terminal is possible
- Models in EX i and EX d

RQ with UST



Main Measurements Information in mm (PN 40 / Class 300)

Typ	RQ 10	RQ 15	RQ 20	RQ 25	RQ 32	RQ 40	RQ 50	RQ 65
L	140	140	150	150	160	170	170	190
H	255	265	265	270	270	280	280	290
Ø D	90	95	105	115	140	150	165	185

Typ	RQ 80	RQ 100	RQ 150	RQ 200	RQ 250	RQ 300
L	200	200	300	400	500	600
H	300	310	330	360	385	410
Ø D	200	235	300	375	450	515

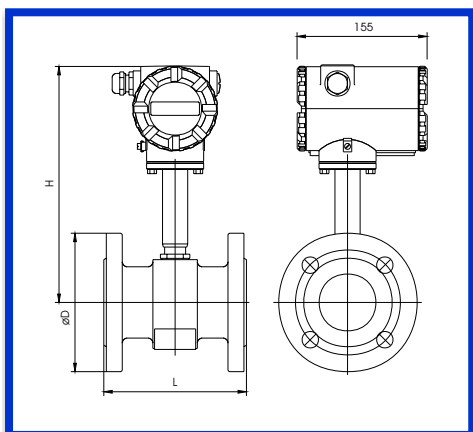



RQ Turbine Flow Meter with AG 81, AG 82, AG 83

Pulse Trigger

The pulse triggers consist of the pick up housing with the pick-up installed and the terminal box with installed preamplifier and the connection terminals. There are three types available depending on the temperatures of the liquid being measured:

Certificate of compliance:
Zündschutzarten:

DMT 00 ATEX E 062 X
II 2G EEx ib II C T6/5/4
Supply circuit fail-safe
 $U_o = 20\text{ V}$
 $I_i = 50\text{ mA}$
 $P = 160\text{ mW}$
 $L_i = 1\text{ mH}$
 $C_i = 25\text{ nF}$

Casing protection type:
Allowable ambient temperature:
Cable specification:

IP 65 according to DIN 40050
-40 to +80°C
Type LiYCY 2 x 0.75 paired, shielded
max. 150 ohms/wire, max. length 1000 m
Color: sky blue, RAL 5015

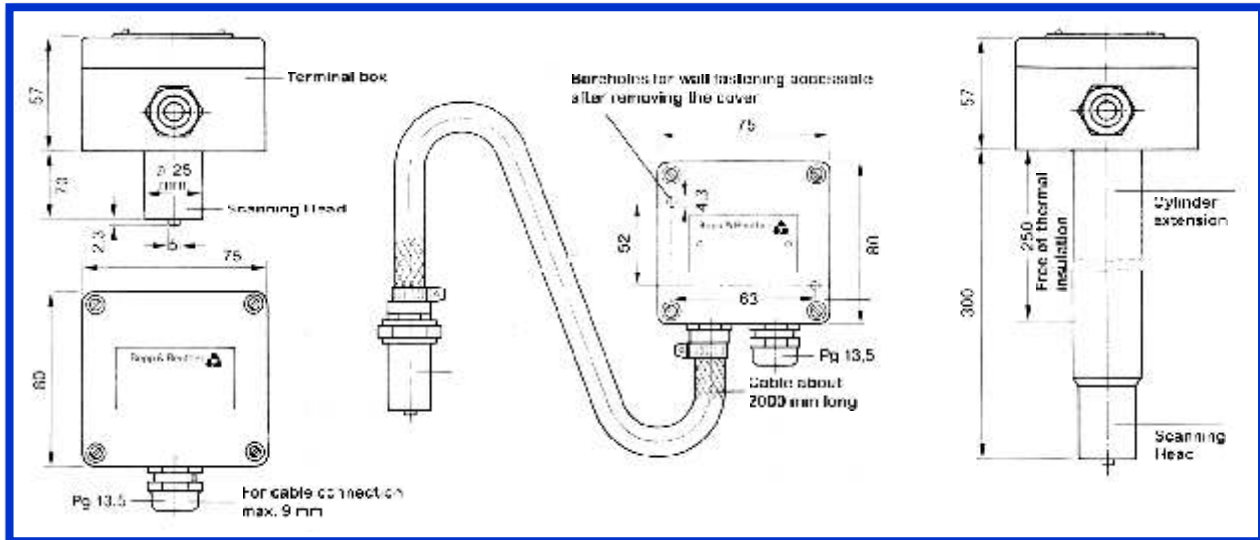

Pulse Trigger

Type Ag 81	Type Ag 82	Type Ag 83
-40°C to +80°C/T 6	-65°C to +80°C/T 6 -65°C to +100°C/T 5 -65°C to +1350°C/T 4 -65°C to +180°C/T 3	-200°C to +80°C/T 6 -200°C to +100°C/T 5 -200°C to +135°C/T 4 -200°C to +200°C/T 3 -200°C to +250°C/T 2

For custody transfer (fiscal metering), the turbine meters should be equipped with two pulse triggers. For calibration using a prover loop, equipping with two pulse triggers is recommended.

The resulting double pulse series provides the capability for error detection based on a pulse comparison in the serially connected computer or converter device.

Installation Arrangement

- Installation position: horizontal
- Pulse pick-up: below the meter

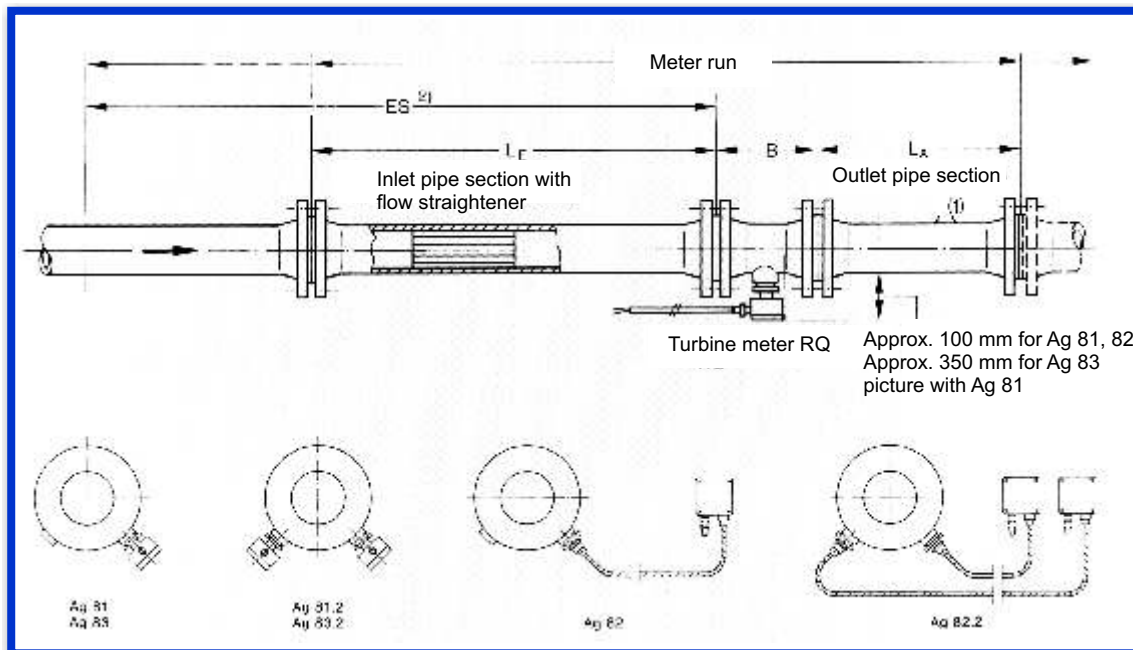

Materials for Inlet and Outlet Sections

Material Group	Materials			
	Flange	Pipe	Tube bundle	
			³ DN 65	³ DN 80
F	1.4571	1.4571	1.4571	
F 2	1.0425 1.0432	1.0305	1.4571	1.0305

DN	Inlet section length	Outlet section length
10	---	---
15	180*	160
20	240*	160
25	250	200
32	320	160
40	400	200
50	500	250
65	650	325
80	800	400
100	1000	500
150	1500	750
200	2000	1000
250	2500	1250
300	3000	1500

The indicated lengths are to be maintained. These are prescribed and binding for custody transfer (fiscal metering). When calibrating the meter at the manufacturing plant, the inlet and outlet sections are to be included in the calibration.

*(12 x DN)

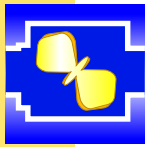

Turbine Meter Profile

Requesting company		Specialist	
Address		Phone	
Request / order no.		Date	
Our offer / order no.		Date	
1. Material to be Measured			
1.1	Name and composition (chemical formula)		
1.2	Chemically pure	<input type="checkbox"/> Yes <input type="checkbox"/> No	
1.3	Impurities and contaminants in %		
1.4	Temperature	min. °C, normal °C, max. °C	
1.5	Density	Kg/m ³ at °C	
1.6	Viscosity at various temperatures (indicate unit in mPas, mm ² /s)	At °C η =	At °C η =
		At °C η =	At °C η =
2. Materials			
2.1	Which materials are corrosion resistant?		
2.2	Which materials are not corrosion resistant?		
2.3	Which material may not be used?		
3. Operating Values			
3.1	Existing pipeline	DN / ANSI	PN
3.2	Flange	DN / ANSI	
3.3	Operating overpressure at the installation location (indicate in bars)	max.	min.
3.4	For limitation of quantity and control indicate in bars	Inlet pressure	Back pressure
3.5	Flow in L/min. Or m ³ /h	min.	Normal max.
3.6	Number of daily operating hours for the meter		
3.7	Average total quantity daily in m ³		
4. Type of System			
4.1	Use for	<input type="checkbox"/> Internal measurement <input type="checkbox"/> Fiscal metering	
4.2	Type of conveyance	<input type="checkbox"/> Piston pump <input type="checkbox"/> Centrifugal pump <input type="checkbox"/> Free pressure gradient	
4.3	In case of pump operation, installation in	<input type="checkbox"/> Suction line <input type="checkbox"/> Pressure line	
4.4	Maximum pump output, for example, m ³ /h		
4.5	Filter available	<input type="checkbox"/> Yes <input type="checkbox"/> No	Mesh width

Bopp & Reuther

Messtechnik GmbH

Postfach 1709

67327 Speyer

Am Neuen Rheinhafen 4

67346 Speyer

Telefon +49 (6232) 657 0

Telefax +49 (6232) 657 505

Internet: www.burmt.de

eMail: info@burmt.de